

SEMINATRICE SEMOVENTE

BOBY 730

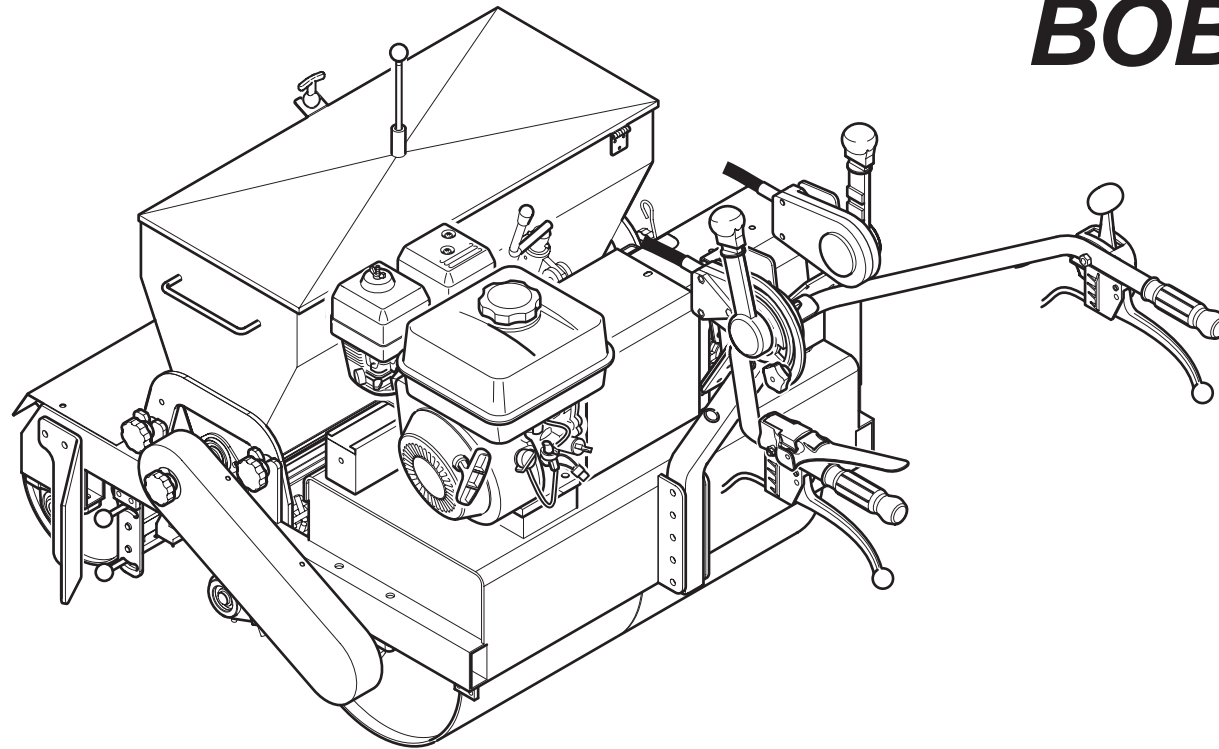

R2 s.a.s. di Rinaldi Roberto & C.

40060 Toscanella di Dozza (Bologna) Italy - Via Valsellustra, 25-29

Tel. +39.0542.672100 • Fax +39.0542.674391

CATALOGO PARTI DI RICAMBIO
SPARE PARTS CATALOGUE
CATALOGUE DE PIECES DETACHEES
ERSATZTEILKATALOG
CATALOGO DE PIEZAS DE REPUESTO

Cod. 045 rev.1

Edizione 05/2007

SIMBOLOGIA • SYMBOLS • SYMBOLES UTILISES • SYMBOLE • SIMBOLOGIA

I

Nella colonna CODICE di ogni distinta può essere presente uno di questi simboli:



Parte di ricambio momentaneamente priva di codice.

Per identificarla occorre indicare:

- Numero della tavola
- Numero di posizione
- Modello e matricola della macchina.

GB

In the CODED column of each list, you find one of following symbols:



Spare part temporarily uncoded.

To identify the part you must specify:

- Table code
- Position number
- Machine model and serial number.

F

Dans la colonne CODE de chaque liste Vous pouvez trouver un des symboles suivants:



Pièce de réchange temporairement sans code.

Pour son identification, il faut spécifier:

- Code du tableau
- Numéro de position
- Modèle et numéro de fabrique machine.

D

Die Reihe Anmerkungen jeder CODE kann ein folgender Symbole zeigen:



Ersatzteil hat vorübergehend keinen Code.

Um diesen Ersatzteil angeben zu können, müssen Sie:

- Code Tabelle
- Positionsnummer
- Maschinenmodell und -nummer.

E

La columna CÓDIGO de cada lista puede presentar uno de los símbolos siguientes:



Repuesto actualmente falto de código.

Para la identificación del repuesto es necesario indicar:

- Código tabla
- Número de posición
- Modelo y número de serie máquina.



Parte di ricambio avente ulteriori parti di ricambio interne.

Per identificare le singole parti interne occorre andare alla tavola di corrispondente denominazione.



Spare part consisting of more internal spare parts.

To find the single internal parts, please refer to the relevant description table.



Pièce de réchange comprenant des pièces de rechange à l'intérieur.

Pour l'identification de pièces individuelles, se référer au tableau descriptif correspondant.



Ersatzteil hat weitere Ersatzteile auf der Innenseite.

Für die Identifikation der einzelnen Innerteile, die entsprechende Benennungstabelle nachschlagen.



Ruesto que consta de sucesivos repuestos internos.

Para la identificación de las partes internas distintas, ver tabla descriptiva correspondiente.



Parte di ricambio con variabili dimensionali o di quantità.

Occorre specificare il modello e la matricola della macchina individuale.



Spare part with dimension or quantity variables.

Always specify the machine model and serial number, given in the identification plate.



Pièce détachée avec variables dimensionnelles o de quantité.

Spécifier toujours le modèle et le numéro de fabrique de la machine,



Ersatzteil mit variablen Maßen oder Menge.

Bitte, Modell und Fabriknummer der



Repuesto con variables dimensionales o de cantidad.

Declarar siempre el modelo y el número de serie de la máquina,

**COME ORDINARE I RICAMBI • HOW TO ORDER SPARE PARTS • COMMANDE DES PIÈCES DÉTACHÉES •
ANFRANGE VON ERSATZTEILEN • PEDIDO DE LOS REPUESTOS**

Per ordinare le parti di ricambio Vi preghiamo cortesemente di fornire al Servizio Assistenza tutte le seguenti informazioni:

- Modello, tipo e numero di matricola della macchina.
- Codice, descrizione e quantità delle parti di ricambio che si intendono ordinare.

Inoltre all'ordine sarà necessario precisare:

- Ragione sociale, indirizzo completo, recapito telefonico e telefax.
- Indirizzo completo al quale spedire le parti di ricambio.
- Eventuale mezzo di trasporto/vettore da utilizzare preferenzialmente.

When ordering spare parts, please supply After Sales Service the following information:

- Machine model, type and serial number
- Code, description and quantity of the spare parts you wish to order.

In addition to what above, add also:

- Corporate name, address, phone and fax number.
- Delivery address.
- Preferential transport mean/carrier.

Pour commander les pièces de rechange nous vous prions de bien vouloir transmettre au Service Après-Vente les indications suivantes:

- Modèle, type et numéro de série de la machine.
- Code, description et quantité des pièces de rechange commandées.

De plus, indiquer dans la commande:

- Nom de la société, adresse complète, numéro de téléphone et de télécopieur.
- Adresse complète pour l'expédition.
- Eventuel moyen de transport/expéditeur préférentiel.

Um Ersatzteil zu bestellen, bitten wir Sie höflichst, dem Kundendienst alle nachfolgend angeführten Angaben zu machen:

- Modell, Typ und Matrikel-Nr. der Maschine.
- Code, Beschreibung und Anzahl der Ersatzteile, die man bestellen möchte.

Außerdem sollte man bei der Bestellung angeben:

- Name der Firma, vollständige Adresse, Telefon und Fax-nummer.
- Vollständige Adresse, an die Ersatzteile zu senden sind.
- Von Ihnen gewünschtes Transportmittel / Transport-unternehmen.

Para el pedido de repuestos, Le rogamos se sirvan suministrar al Servicio Asistencia todas las indicaciones siguientes:

- Modelo, tipo y número de matricula de la máquina.
- Código, descripción y cantidad de los repuestos pedido.

Además, se ruega detallar lo siguiente:

- Razón social, dirección completa, teléfono y telefax.
- Dirección completa a la que se deben enviar los repuestos.
- Eventual medio/agente de transporte que se desea utilizar.

INDICE DELLE TAVOLE • TABLE INDEX • INDEX DES TABLEAUX

01.0	RULLO POSTERIORE CON DIFFERENZIALE	REAR ROLLER WITH DIFFERENTIAL GEAR	ROULEAU ARRIERE AVEC DIFFERENTIEL
02.0	MONTAGGIO RULLO ANTERIORE E POSTERIORE	FRONT AND REAR ROLLER ASSEMBLY	MONTAGE ROULEAUX AVANT ET ARRIERE
03.0	MONTAGGIO RULLO RASTRELLO	RAKE ROLLER ASSEMBLY	MONTAGE ROULEAU RATEAU
04.0	CASSONETTO SEMINATRICE	SEEDER BOX	CAISSON SEMOIR
05.0	MOTORE E TRASMISSIONE	ENGINE AND TRANSMISSION	MOTEUR ET TRANSMISSION
06.0	COMANDI OPERATORE	OPERATION CONTROLS	COMMANDES OPERATEUR
07.0	CARTER E ACCESSORI	COVERS AND ACCESSORIES	CARTERS ET ACCESSOIRES
08.0	MATERIALE ELETTRICO	ELECTRIC INSTALLATION	INSTALLATION ELECTRIQUE
09.0	MONTAGGIO RULLO ANTERIORE E POSTERIORE	FRONT AND REAR ROLLER ASSEMBLY	MONTAGE ROULEAUX AVANT ET ARRIERE
10.0	MONTAGGIO RULLO ANTERIORE	FRONT ROLLER ASSEMBLY	MONTAGE ROULEAUX AVANT

TABELLEN-VERZEICHNIS • INDICE DE LAS TABLAS

01.0	HINTERE ROLLE MIT DIFFERENZIAL	RODILLO TRASERO CON DIFERENCIAL
02.0	MONTAGE VORDERE UND HINTERE ROLLEN	MONTAGE RODILLOS DELANTERO Y TRASERO
03.0	MONTAGE RIEMENSCHLEIBE	MONTAJE RODILLO RASTRILLO
04.0	KASTEN DRILLMASCHINE	CAJA SEMBRADORA
05.0	MOTOR UND TRANSMISSION	MOTOR Y TRANSMISIÓN
06.0	BEDIENERSTEUERUNGEN	MANDOS OPERADOR
07.0	SCHUTZABDECKUNGEN UND ZEBÖHR	CÁRTERES Y ACCESORIOS
08.0	ELEKTROANLAGE	INSYALLACION ELECTRICA
09.0	MONTAGE VORDERE UND HINTERE ROLLEN	MONTAGE RODILLOS DELANTERO Y TRASERO
10.0	MONTAGE VORDERE ROLLEN	MONTAGE RODILLOS DELANTERO



RULLO POSTERIORE CON DIFFERENZIALE
REAR ROLLER WITH DIFFERENTIAL GEAR
ROULEAU ARRIERE AVEC DIFFERENTIEL
HINTERE ROLLE MIT DIFFERENZIAL
RODILLO TRASERO CON DIFERENCIAL

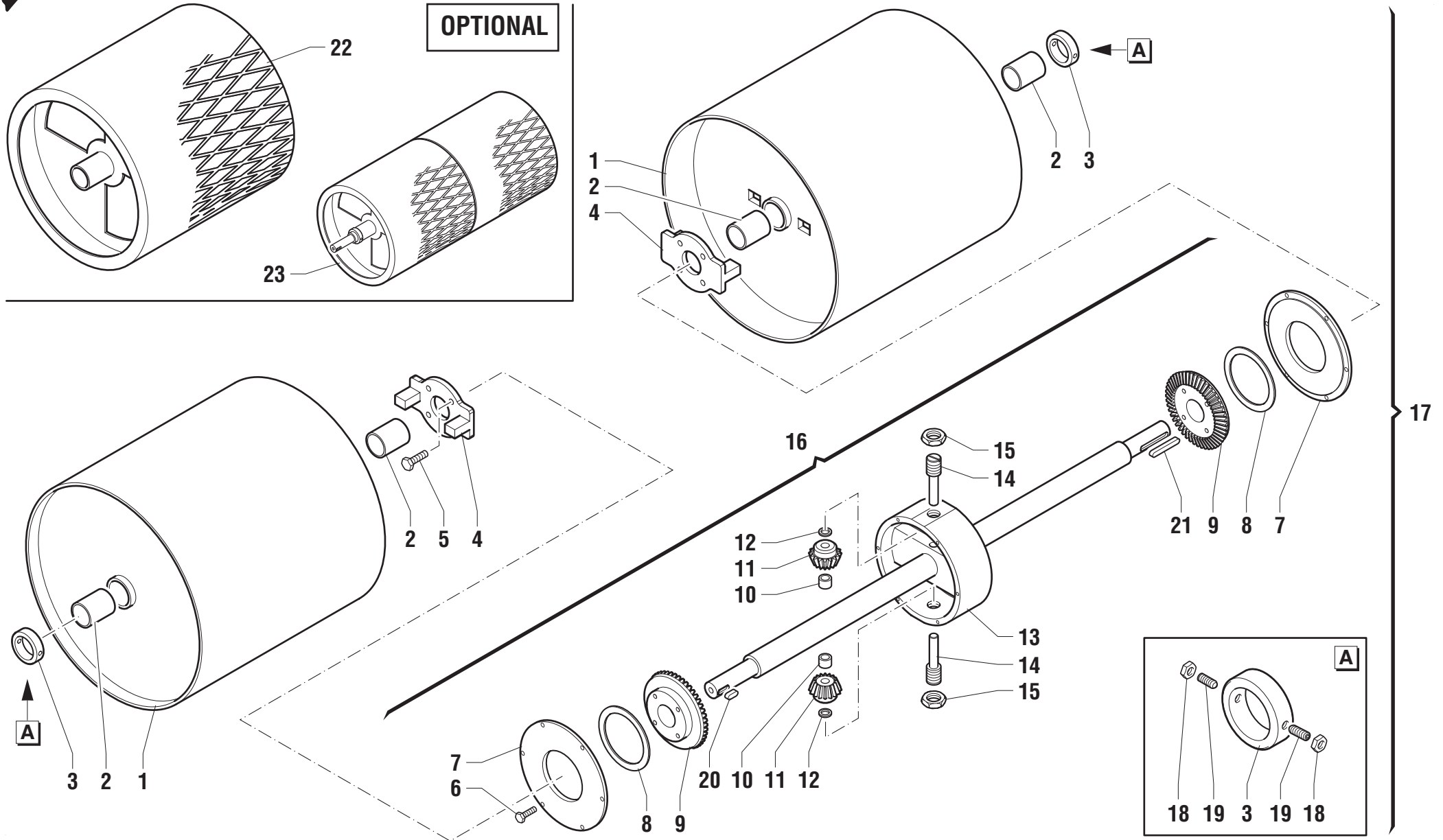

<i>Rif.</i>	<i>CODICE</i>	<i>Qty</i>	<i>Descrizione</i>	<i>Description</i>	<i>Designation</i>	<i>Benennung</i>	<i>Denominaciones</i>
1	045.003	2	RULLO POSTERIORE	REAR ROLLER	ROULEAU ARRIERE	HINTERE ROLLE	RODILLO TRASERO
2	050.298	4	BOCCOLA	BUSHING	DOUILLE	BÜCHSE	CASQUILLO
3	045.023	2	DISTANZIALE ESTERNO	EXTERNAL SPACER FOR	ENTRETOISE EXTERIEURE	AUSSERES ABSTANDSTÜCK	ESPACIADOR EXTERIOR
			FERMA RULLO	ROLLER LOCKING DEVICE	ARRETE-ROULEAU	ROLLENSPERRE	BLOQUEO RODILLO
4	045.011	2	PIASTRA TRASCINAMENTO RULLO	ROLLER DRIVING PLATE	PLAQUE ENTRAINEMENT ROULEAU	MITNEHMERPLATTE ROLLE	PLACA ARRASTRE RODILLO
5	21.0.0.08030	8	VITE	SCREW	VIS	SCHRAUBE	TORNILLO
6	21.0.0.06020	12	VITE	SCREW	VIS	SCHRAUBE	TORNILLO
7	045.010	2	COPERCHIO DIFFERENZIALE	DIFFERENTIAL COVER	COUVERCLE DIFFERENTIEL	DECKEL DIFFERENZIAL	TAPA DIFERENCIAL
8		2	ANELLO RASAMENTO	SHIM	CALE	BEILAGESCHEIBE	ANILLO INTERMEDIO
9	045.006	2	CORONA	RING GEAR	COURONNE	KRANZ	CORONA
10	045.009	2	DISTANZIALE SATELLITE	PLANETARY GEAR DIFFERENTIAL	DIFFERENTIEL PLANETAIRE	DIFFERENZIAL PLANETENRAD	DIFERENCIAL PLANETÁRIO
11	045.007	2	PIGNONE	PINION	PIGNON	RITZEL	PINON
12		2	ANELLO RASAMENTO	SHIM	CALE	BEILAGESCHEIBE	ANILLO INTERMEDIO
13	045.005	1	ALBERO DIFFERENZIALE	DIFFERENTIAL SHAFT	ARBRE DIFFERENTIEL	DIFFERENZIALWELLE	EJE DIFERENCIAL
14	045.008	2	PERNO PER PIGNONE	PINION PIN	AXE PIGNON	ZAPFEN RITZEL	PERNO PIÑÓN
15	31.01.01.0.20	2	DADO	NUT	ECROU	MUTTER	TUERCA
16	045.004	1	DIFFERENZIALE RULLO POSTER.	REAR ROLLER DIFFERENTIAL	DIFFERENTIEL ROULEAU ARRIERE	DIFFERENZIAL HINTERE ROLLE	DIFERENCIAL RODILLOTRASERO
17	045.003	1	RULLO POSTERIORE COMPLETO	COMPLETE REAR ROLLER	ROULEAU ARRIERE COMPLET	KOMPLETTE HINTERE ROLLE	RODILLO TRASERO COMPLETO
18	31.02.00.1.08	4	DADO	NUT	ECROU	MUTTER	TUERCA
19	25.2.1.08020	4	GRANO	SECURITY DOWEL	GRAIN	STIFT	PERNO DE TOPE
20	35.1.0.08020	2	RULLO POSTERIORE	REAR ROLLER	ROULEAU ARRIERE	HINTERE ROLLE	RODILLO TRASERO
21	35.1.0.08045	1	CHIAVETTA	KEY	CLAVETTE	KEIL	CHAVETA
22	045.075	2	RULLO POSTERIORE A RETE	REAR GRID ROLLER	ROULEAU A GRILLE ARRIERE	HINTERE GITTERWALZE	RODILLO DE REJILLA TRASERO
23	045.076	1	RULLO POST. COMPLETO A RETE	COMPLETE REAR GRID ROLLER	ROULEAU A GRILLE ARRIERE COMPLET	HINTERE GITTERWALZE KOMPLETT	RODILLO DE REJILLA TRASERO COMPLETO





MONTAGGIO RULLO ANTERIORE E POSTERIORE
FRONT AND REAR ROLLER ASSEMBLY
MONTAGE ROULEAUX AVANT ET ARRIERE
MONTAGE VORDERE UND HINTERE ROLLEN
MONTAGE RODILLOS DELANTERO Y TRASERO

Tav. 02.1

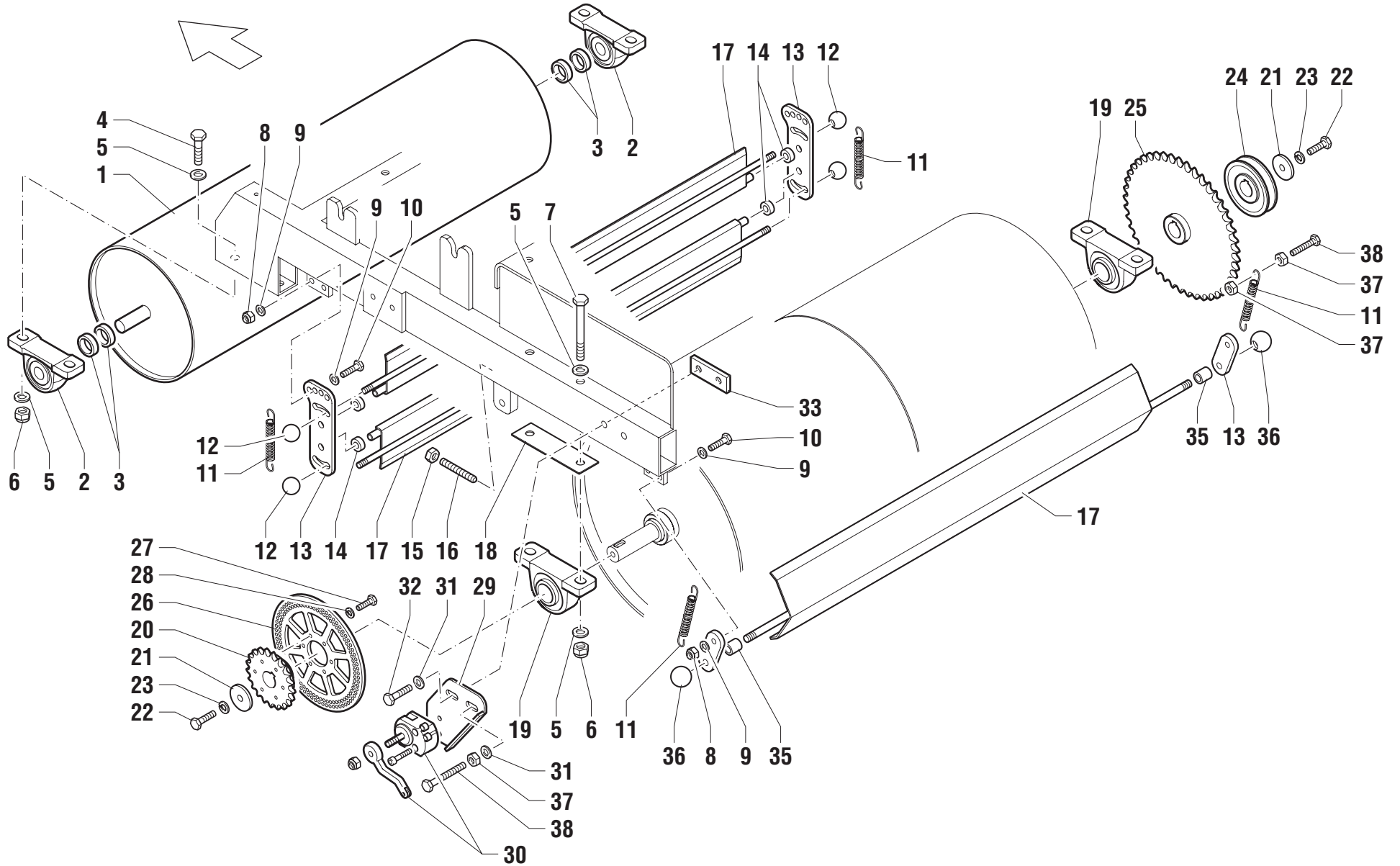

<i>Rif.</i>	<i>CODICE</i>	<i>Qty</i>	<i>Descrizione</i>	<i>Description</i>	<i>Designation</i>	<i>Benennung</i>	<i>Denominaciones</i>
1	045.002	1	RULLO ANTERIORE	FRONT ROLLER	ROULEAU AVANT	VORDERE ROLLE	RODILLO DELANTERO
2	AUCP204	2	SUPPORTO	SUPPORT	SUPPORT	LAGER	SOPORTE
3	045.029	4	DISTANZIALE	SPACER	ENTRETOISE	ABSTANDSTUECK	SEPARADOR
4	20.0.0.12040	4	VITE	SCREW	VIS	SCHRAUBE	TORNILLO
5	15.0.0.00.012	16	RONDELLA PIANA	PLAIN WASHER	RONDELLE PLANE	ABSTANDSRING	ARANDELA LLANA
6	30.02.00.012	8	DADO AUTOBLOCCANTE	STOP NUT	ECROU DE SURETE	SPERRMUTTER	TUERCA AUTOTRABADORA
7	20.0.0.12110	4	VITE	SCREW	VIS	SCHRAUBE	TORNILLO
8	30.01.00.008	8	DADO AUTOBLOCCANTE	STOP NUT	ECROU DE SURETE	SPERRMUTTER	TUERCA AUTOTRABADORA
9	15.0.0.00.008	16	RONDELLA PIANA	PLAIN WASHER	RONDELLE PLANE	ABSTANDSRING	ARANDELA LLANA
10	21.0.0.08025	8	VITE	SCREW	VIS	SCHRAUBE	TORNILLO
11	045.043	4	MOLLA	SPRING	RESSORT	FEDER	RESORTE
12	050.068	4	POMELLO	BALL-GRIP	POMMEAU	KUGELGRIFF	POMO
13	045.013	2	SUPPORTO PULISCI RULLO	ROLLER CLEANING PLATE SUPPORT	SUPPORT TOLE NETTOYAGE ROULEAU	HALTERUNG ROLLENREINIGUNGSBLECH	SOPORTE CHAPA LIMPIEZA RODILLO
14	045.012	4	DISTANZIALE	SPACER	ENTRETOISE	ABSTANDSTUECK	SEPARADOR
15	31.02.00.1.08	2	DADO	NUT	ECROU	MUTTER	TUERCA
16	25.0.0.08060	2	BARRA FILETTATA	THREADED BAR	BARE FILETEE	STANGE SCHRAUBEN	BARRA FILETEAR
17	045.014	2	LAMIERA PULISCI RULLO	ROLLER CLEANING PLATE	TOLE NETTOYAGE ROULEAU	REINIGUNGSBLECH ROLLE	CHAPA LIMPIEZA RODILLO
18	045.022	2	DISTANZIALE PER SUPPORTO	SUPPORT SPACER	ENTRETOISE SUPPORT	ABSTANDSTÜCK HALTERUNG	ESPACIADOR SOPORTE
19	AUCP205	2	SUPPORTO	SUPPORT	SUPPORT	LAGER	SOPORTE
20	045.027	1	PIGNONE	PINION	PIGNON	RITZEL	PINON
21	15.1.0.01.010	2	RONDELLA	WASHER	RONDELLE	SCHEIBE	ARANDELA
22	21.0.0.10025	2	VITE	SCREW	VIS	SCHRAUBE	TORNILLO
23	16.01.00.010	2	GROWER	GROWER	GROWER	GROWER	GROWER
24	045.021	1	PULEGGIA DI TRASMISSIONE	DRIVING PULLEY	POULIE MOTRICE	ANTRIEBSSCHEIBE	POLEA MOTRIZ
25	045.025	1	CORONA	RING GEAR	COURONNE	KRANZ	CORONA
26	045.040	1	DISCO FRENO	BRAKE DISC	DISQUE DE FREIN	BREMSSCHEIBE	DISCO FRENO
27	21.0.0.05016	6	VITE	SCREW	VIS	SCHRAUBE	TORNILLO
28	15.0.0.00.005	6	RONDELLA PIANA	PLAIN WASHER	RONDELLE PLANE	ABSTANDSRING	ARANDELA LLANA
29	045.039	1	SUPPORTO PINZA FRENO	BRAKE CALIPER SUPPORT	SUPPORT ETRIER DE FREIN	HALTERUNG BREMSSATTEL	SOPORTE PINZA FRENO
30	050.322	1	PINZA FRENO	BRAKE CALIPER	ETRIER DE FREIN	BREMSSATTEL	PINZA FRENO
31	15.0.0.00.010	4	RONDELLA PIANA	PLAIN WASHER	RONDELLE PLANE	ABSTANDSRING	ARANDELA LLANA





MONTAGGIO RULLO ANTERIORE E POSTERIORE
FRONT AND REAR ROLLER ASSEMBLY
MONTAGE ROULEAUX AVANT ET ARRIERE
MONTAGE VORDERE UND HINTERE ROLLEN
MONTAGE RODILLOS DELANTERO Y TRASERO

Tav. 02.1

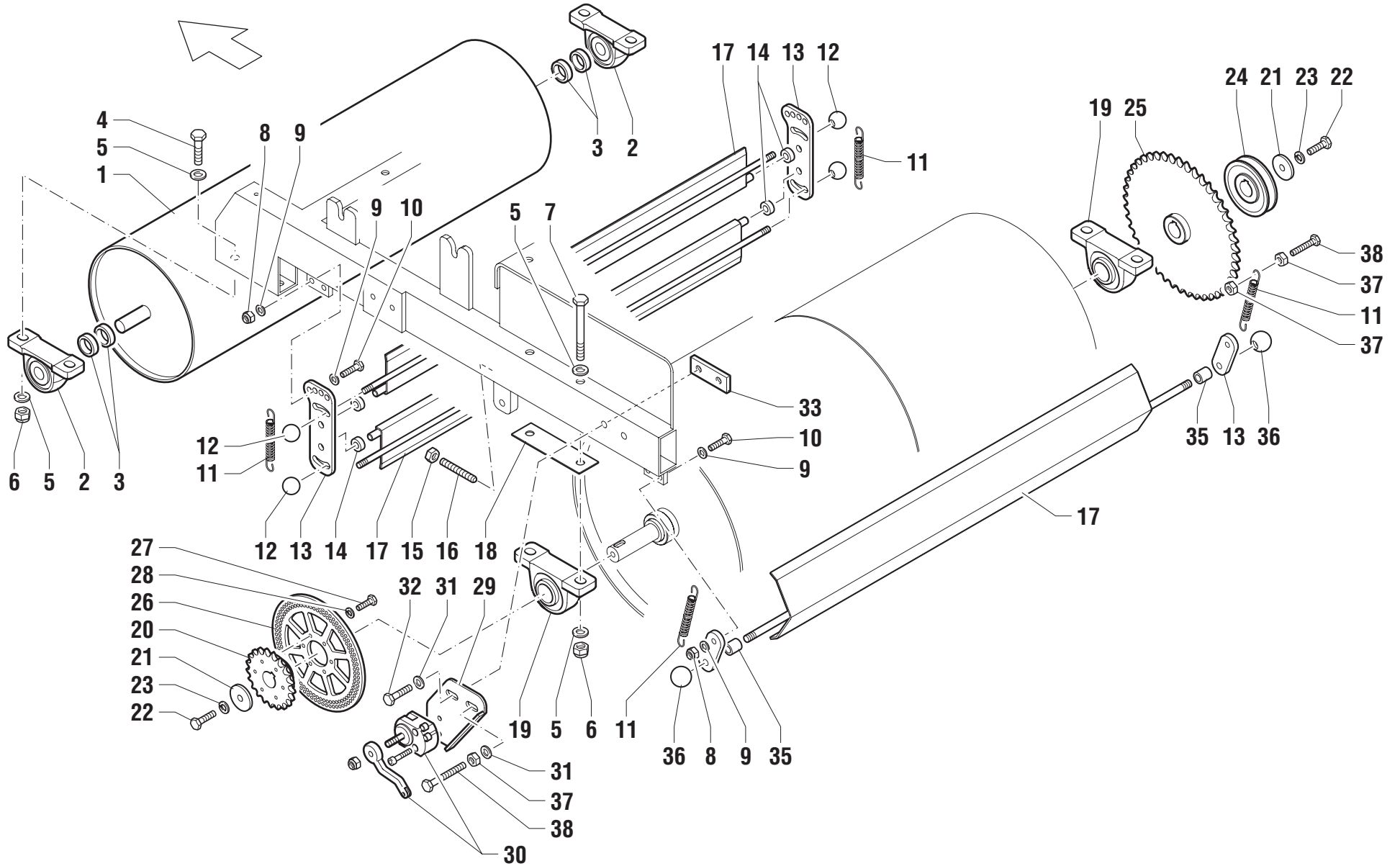



MONTAGGIO RULLO RASTRELLO
RAKE ROLLER ASSEMBLY
MONTAGE ROULEAU RATEAU
MONTAGE RIEMENSCHLEIBE
MONTAJE RODILLO RASTRILLO

Tav. 03.0

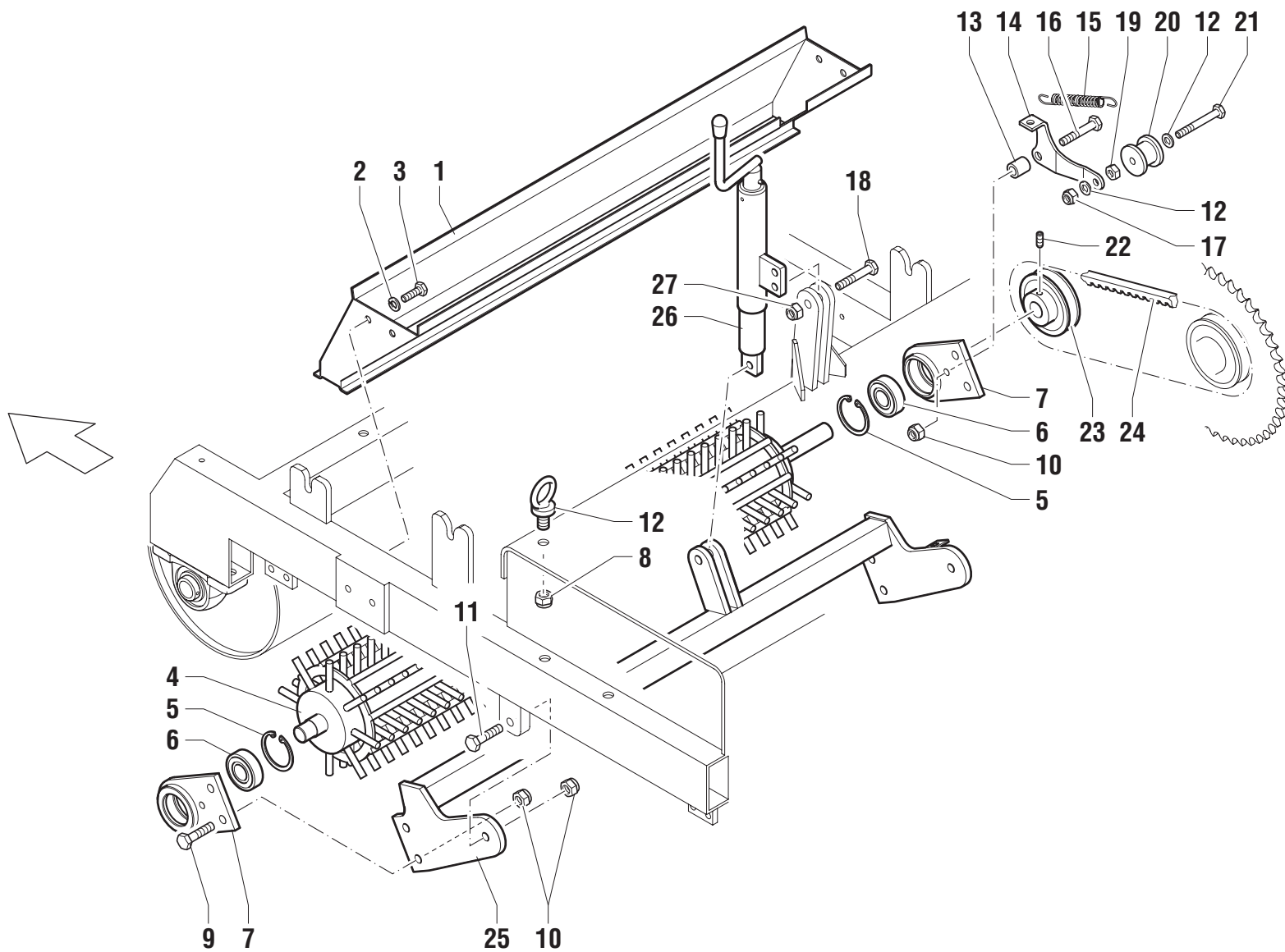

<i>Rif.</i>	<i>CODICE</i>	<i>Qty</i>	<i>Descrizione</i>	<i>Description</i>	<i>Designation</i>	<i>Benennung</i>	<i>Denominaciones</i>
1	045.050	1	SCIVOLO	DEBRIS CHUTE	GOULOTTE D'AMENEE EBOULIS	BOHRMEHLRUTSCHE	PLANO DESCARGA DETRITOS
2	15.0.0.00.008	6	RONDELLA PIANA	PLAIN WASHER	RONDELLE PLANE	ABSTANDSRING	ARANDELA LLANA
3	21.0.0.08016	4	VITE	SCREW	VIS	SCHRAUBE	TORNILLO
4	045.015	1	RULLO RASTRELLO	RAKE ROLLER	ROULEAU RATEAU	RIEMENSCHLEIBE	RODILLO RASTRILLO
5	18.00.00.047	2	ANELLO ELASTICO	SNAP RING	ANNEAU RESSORT	SICHERUNGSRING	ANILLO ELASTICO
6	A62042RS	2	CUSCINETTO	BEARING	PALIER	LAGERSCHALE	COJINETE
7	045.017	2	SUPPORTO LATERALE	SIDE SUPPORT	SUPPORT LATERAL	SEITLICHE HALTERUNG	SOPORTE LATERAL
8	30.02.00.014	2	DADO AUTOBLOCCANTE	STOP NUT	ECROU DE SURETE	SPERRMUTTER	TUERCA AUTOTRABADORA
9	21.0.0.10030	4	VITE	SCREW	VIS	SCHRAUBE	TORNILLO
10	30.02.00.010	7	DADO AUTOBLOCCANTE	STOP NUT	ECROU DE SURETE	SPERRMUTTER	TUERCA AUTOTRABADORA
11	20.0.0.10040	2	VITE	SCREW	VIS	SCHRAUBE	TORNILLO
12	050.319	2	GOLFARE	EYEBOLT	CHEVILLE A OEILLET	ÖSENSCHRAUBE	ARGOLLA
13	045.019	1	BOCCOLA TENDITORE	TIGHTENER BUSHING	DOUILLE TENDEUR	SPANNERBUCHSE	CASQUILLO TENSOR
14	045.018	1	TENDITORE CINGHIA	BELT TIGHTENER	TENDEUR COURROIE	RIEMENSPELLNER	TENSOR CORREA
15	045.043	1	MOLLA	SPRING	RESSORT	FEDER	RESORTE
16	20.0.0.10050	1	VITE	SCREW	VIS	SCHRAUBE	TORNILLO
17	30.02.00.008	1	DADO AUTOBLOCCANTE	STOP NUT	ECROU DE SURETE	SPERRMUTTER	TUERCA AUTOTRABADORA
18	20.0.0.10045	2	VITE	SCREW	VIS	SCHRAUBE	TORNILLO
19	31.02.00.0.08	1	DADO	NUT	ECROU	MUTTER	TUERCA
20	090.036	1	RULLO	ROLLER	ROULEAU	WALZE ROLLE	RODILLO
21	20.0.0.08050	1	VITE	SCREW	VIS	SCHRAUBE	TORNILLO
22	25.2.1.08020	1	GRANO	SECURITY DOWEL	GRAIN	STIFT	PERNO DE TOPE
23	045.020	1	PULEGGIA RULLO RASTRELLO	RAKE ROLLER PULLEY	POULIE ROULEAU RATEAU	RIEMENSCHLEIBE RECHENROLLE	POLEA RODILLO RASTRILLO
24	050.312	1	CINGHIA	BELT	COURROIE	RIEMEN	CORREA
25	045.016	1	SUPPORTO RULLO RASTRELLO	RAKE ROLLER SUPPORT	SUPPORT ROULEAU RATEAU	HALTERUNG RECHENROLLE	SOPORTE RODILLO RASTRILLO
26	045.030	1	REGISTRO	ADJUSTER	REGLAGE	REGULATOR	AJUSTE
27	30.02.00.090	2	DADO AUTOBLOCCANTE	STOP NUT	ECROU DE SURETE	SPERRMUTTER	TUERCA AUTOTRABADORA





CASSONETTO SEMINATRICE
SEEDER BOX
CAISSON SEMOIR
KASTEN DRILLMASCHINE
CAJA SEMBRADORA

Tav. 04.0

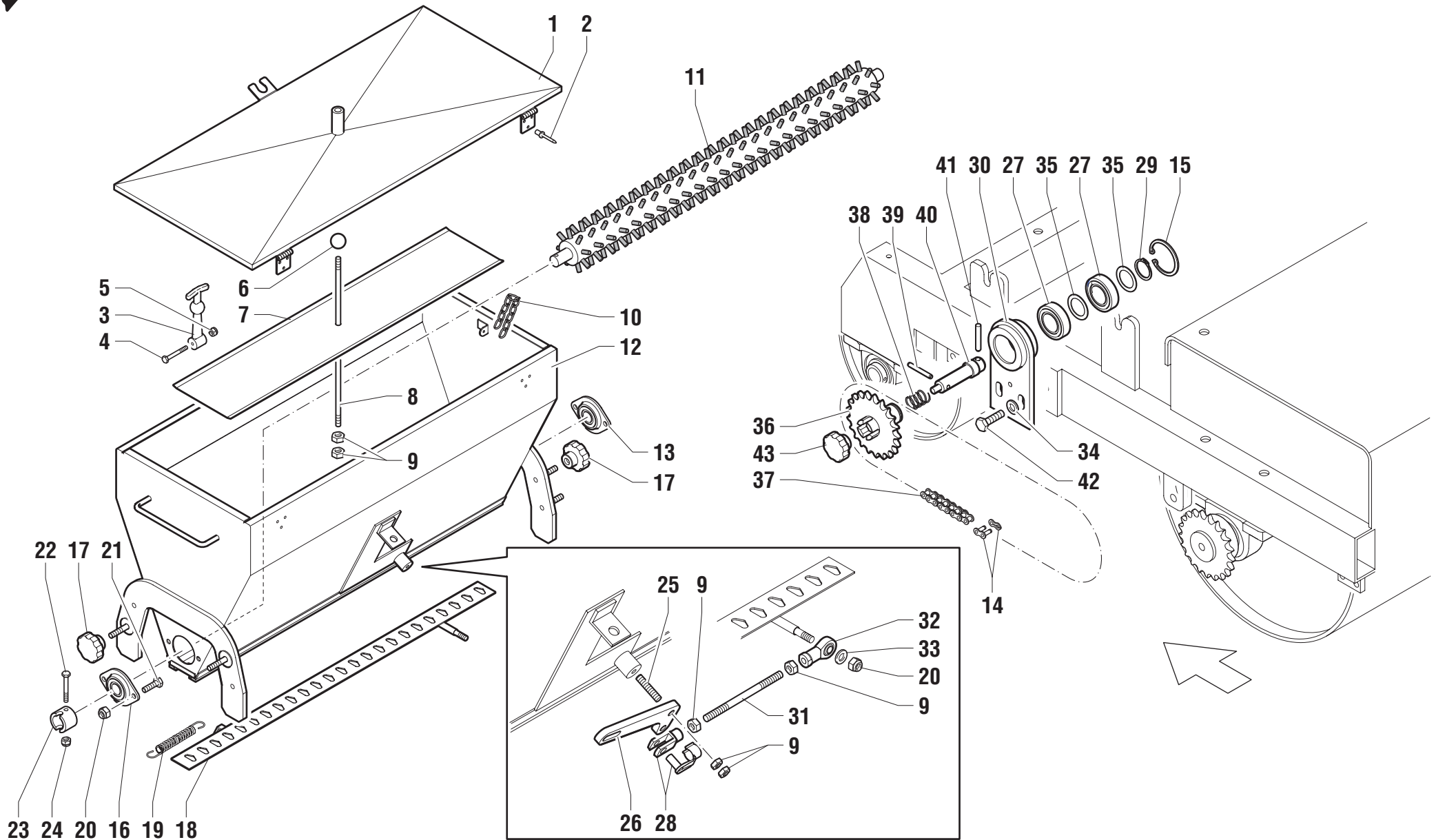

Rif.	CODICE	Qty	Descrizione	Description	Designation	Benennung	Denominaciones
1	045.045/F	1	COPERCHIO	COVER	COUVERCLE	DECKEL	TAPA
2	 045.045	6	RIVETTO	RIVET	RIVET	NIETVERBINDUNG	REMACHE
3	050.066	1	TIRANTE IN GOMMA	RUBBER TIE-ROG	TIRANT CAOUTCHOUC	GUMMI-ZUGSTANGE	TIRANTE DE GOMA
4	21.0.0.04035	1	VITE	SCREW	VIS	SCHRAUBE	TORNILLO
5	30.02.00.004	1	DADO AUTOBLOCCANTE	STOP NUT	ECROU DE SURETE	SPERRMUTTER	TUERCA AUTOTRABADORA
6	050.068	1	POMELLO	BALL-GRIP	POMMEAU	KUGELGRIFF	POMO
7	045.046	1	LAMIERA LIVELLO SEME	SEED LEVEL PLATE	TOLE NIVEAU GRAINES	BLECH SAMENSTAND	CHAPA NIVEL SEMILLA
8	045.047	1	ASTA FILETTATA	THREADED BAR	TIGE FILETEE	GEWINDESTANGE	BARRA ROSCADA
9	31.02.00.1.08	6	DADO	NUT	ECROU	MUTTER	TUERCA
10	 045.045	1	CATENA COPERCHIO	CHAIN	CHAÎNE	KETTE	CADENA
11	045.042	1	SPAZZOLA CASSONETTO	BOX BRUSH	BROSSE CAISSON	BÜRSTE KASTEN	CEPILLO CAJA
12	045.045	1	CASSONETTO SEMINATRICE	SEEDER BOX	CAISSON SEMOIR	KASTEN DRILLMASCHINE	CAJA SEMBRADORA
13	BUBPFL204B	1	SUPPORTO	SUPPORT	SUPPORT	LAGER	SOPORTE
14	050.315	1	MAGLIA DI GIUNZIONE	CHAIN JOINT	JOINT DE CHAÎNE	STECKGLIED	UNIÓN DE CADENA
15	18.00.00.047	1	ANELLO ELASTICO	SNAP RING	ANNEAU RESSORT	SICHERUNGSRING	ANILLO ELASTICO
16	BUBPFL204	1	SUPPORTO	SUPPORT	SUPPORT	LAGER	SOPORTE
17	050.313	4	VOLANTINO	HAND WHELL	VOLANT A MAN	HANDRAD	VOLANTE
18	045.045/D	1	BANDELLA CASSONETTO	BOX BAR	RABAT CAISSON	KASTENBAND	BANDA CAJA
19	045.043	1	MOLLA	SPRING	RESSORT	FEDER	RESORTE
20	30.02.00.008	5	DADO AUTOBLOCCANTE	STOP NUT	ECROU DE SURETE	SPERRMUTTER	TUERCA AUTOTRABADORA
21	21.0.0.08016	4	VITE	SCREW	VIS	SCHRAUBE	TORNILLO
22	21.0.0.05040	1	VITE	SCREW	VIS	SCHRAUBE	TORNILLO
23	045.032	1	MANICOTTO DI INNESTO	CLUTCH HOLLOW SHAFT	FOURREAU D'EMBRAYAGE	KUPPLUNGSHÜLSE	MANGUITO EMBRAGUE
24	30.02.00.005	1	DADO AUTOBLOCCANTE	STOP NUT	ECROU DE SURETE	SPERRMUTTER	TUERCA AUTOTRABADORA
25	26.0.0.08025	1	PRIGIONIERO	STUD	PRISONNIER	GEWINDESTIFT	PRISIONERO
26	045.044	1	LEVA	LEVER	LEVIER	HEBEL	PALANCA
27	A60052RS	2	CUSCINETTO	BEARING	PALIER	LAGERSCHALE	COJINETE
28	050.069	1	FORCELLA	FORK	FOURCHE	GABEL	HORQUILLA
29	18.01.00.025	1	ANELLO ELASTICO	SNAP RING	ANNEAU RESSORT	SICHERUNGSRING	ANILLO ELASTICO
30	045.034	1	SUPPORTO PER INNESTO	CLUTCH SHAFT SUPPORT	SUPPORT ARBRE D'EMBRAYAGE	TRÄGER KUPPLUNGSWELLE	SOPORTE EJE EMBRAGUE
31	045.041	1	BARRA FILETTATA	THREADED BAR	BARE FILETEE	STANGE SCHRAUBEN	BARRA FILETEAR





CASSONETTO SEMINATRICE
SEEDER BOX
CAISSON SEMOIR
KASTEN DRILLMASCHINE
CAJA SEMBRADORA

Tav. 04.0

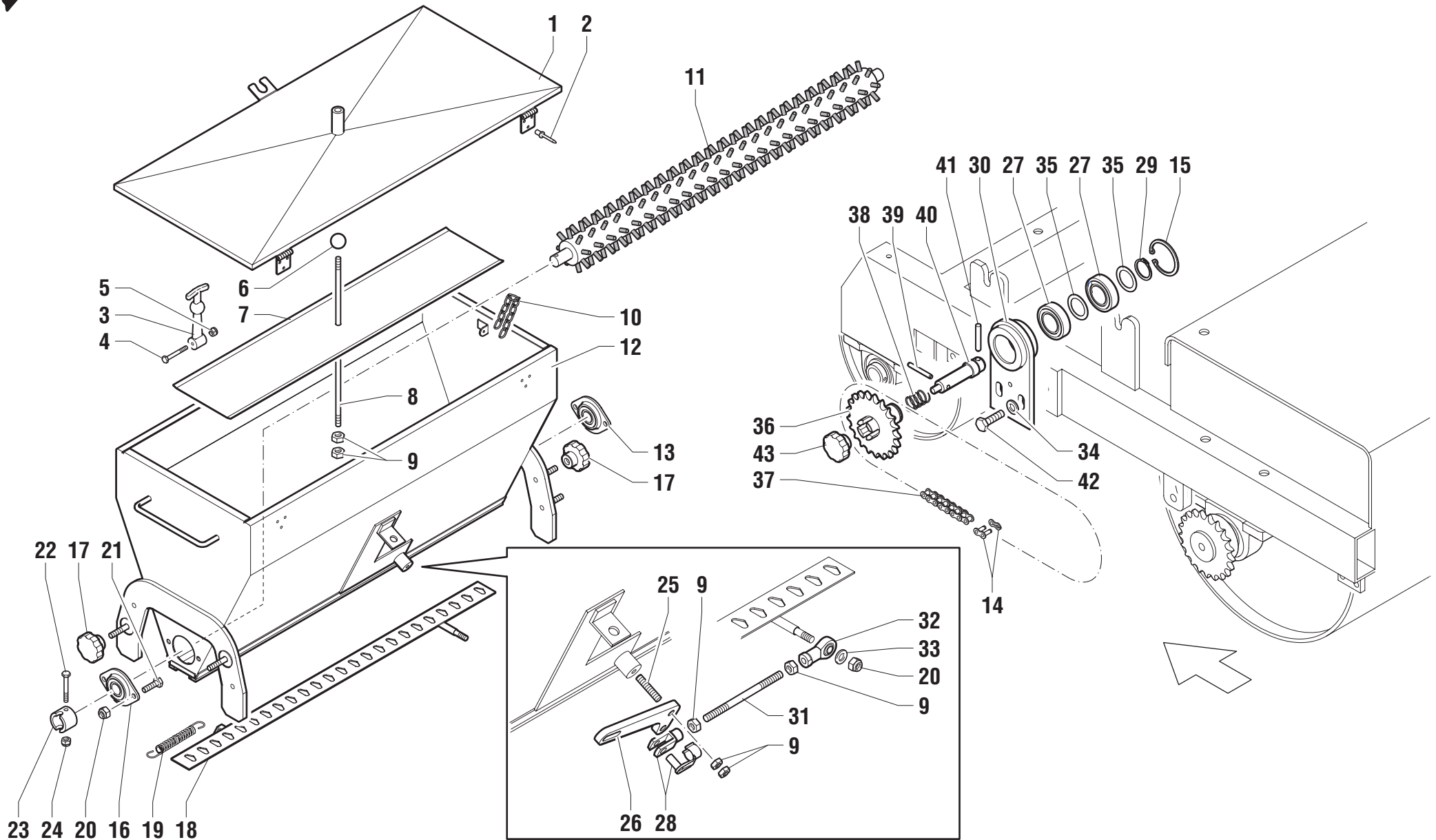

Rif.	CODICE	Qty	Descrizione	Description	Designation	Benennung	Denominaciones
32	050.263	1	SNODO SFERICO	BALL JOINT	JOINT A ROTULE	KUGELGELENK	ARTICULACION DE BOLA
33	15.0.0.00.008	1	RONDELLA PIANA	PLAIN WASHER	RONDELLE PLANE	ABSTANDSRING	ARANDELA LLANA
34	15.0.0.00.010	2	RONDELLA PIANA	PLAIN WASHER	RONDELLE PLANE	ABSTANDSRING	ARANDELA LLANA
35		2	SPESSORE	THICKNESS	EPAISSEUR	ZWISCHENLAGE	ESPESOR
36	045.033	1	CANNOTTO DI INNESTO	CLUTCH TUBE	TUBE D'EMBRAYAGE	KUPPLUNGSROHR	TUBO EMBRAGUE
37	050.314	1	CATENA	CHAIN	CHAÎNE	KETTE	CADENA
38	045.035	1	MOLLA	SPRING	RESSORT	FEDER	RESORTE
39	38.0.0.05028	1	SPINA ELASTICA	SPLIT PIN	BROCHE ELASTIQUE	ZAPFEN FEDRIG	PERNO ELASTICO
40	045.031	1	ALBERINO DI INNESTO	CLUTCH SHAFT	ARBRE D'EMBRAYAGE	KUPPLUNGSWELLE	EJE EMBRAGUE
41	38.0.0.06030	1	SPINA ELASTICA	SPLIT PIN	BROCHE ELASTIQUE	ZAPFEN FEDRIG	PERNO ELASTICO
42	21.0.0.10030	2	VITE	SCREW	VIS	SCHRAUBE	TORNILLO
43	050.030	1	VOLANTINO	HAND WHELL	VOLANT A MAN	HANDRAD	VOLANTE



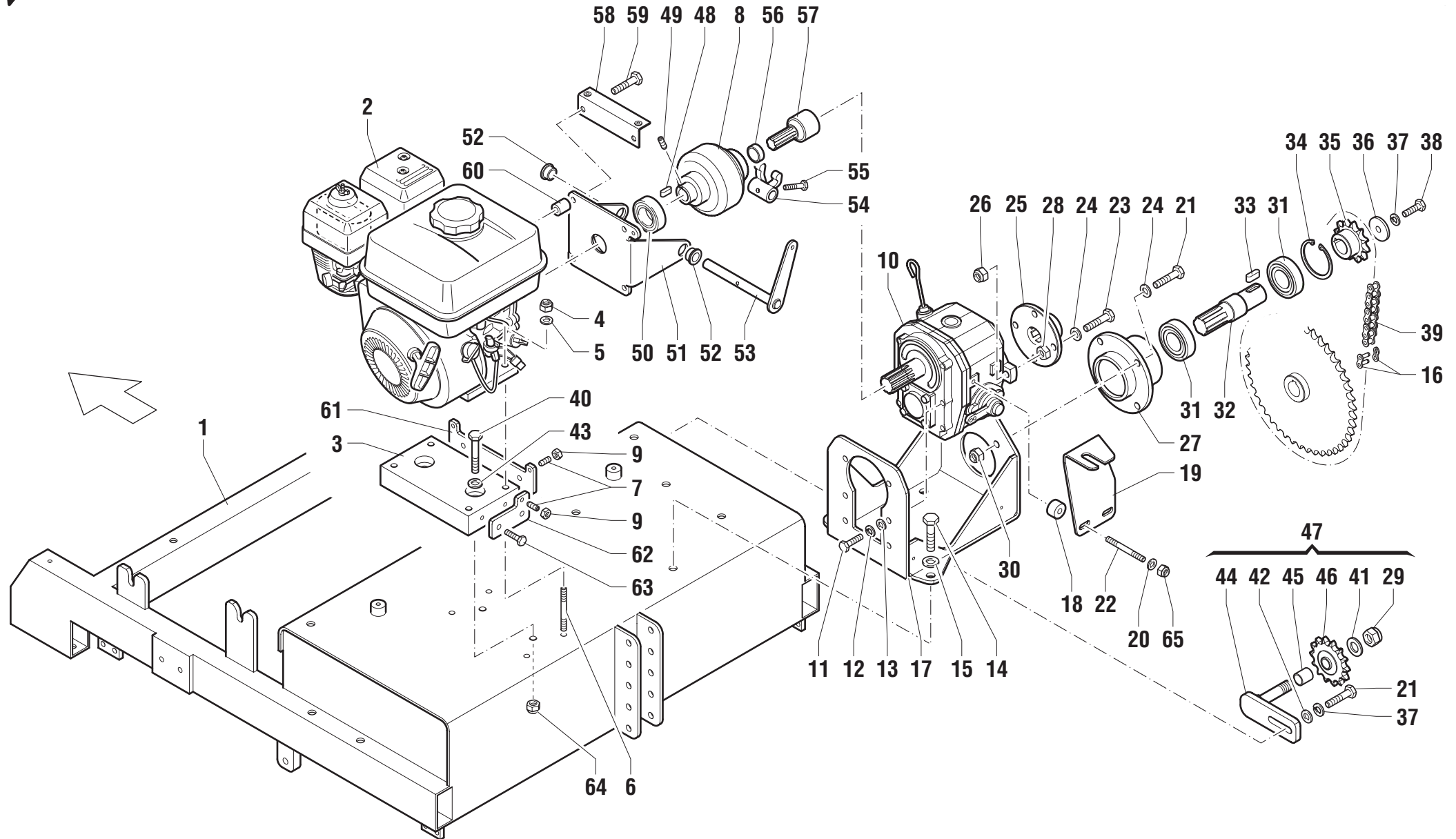

<i>Rif.</i>	<i>CODICE</i>	<i>Qty</i>	<i>Descrizione</i>	<i>Description</i>	<i>Designation</i>	<i>Benennung</i>	<i>Denominaciones</i>
1	045.001	1	TELAIO	FRAME	CHASSIS	RAHMEN	BASTIDOR
2	050.259	1	MOTORE	MOTOR	MOTEUR	MOTOR	MOTOR
3	045.060	1	SPESSORE MOTORE	ENGINE SHIM	CALE MOTEUR	BEILAGESCHEIBE MOTOR	ESPEJOR MOTOR
4	30.03.00.008	4	DADO AUTOBLOCCANTE	STOP NUT	ECROU DE SURETE	SPERRMUTTER	TUERCA AUTOTRABADORA
5	15.0.0.00.008	4	RONDELLA PIANA	PLAIN WASHER	RONDELLE PLANE	ABSTANDSRING	ARANDELA LLANA
6	045.061	4	PRIGIONIERO	STUD	PRISONNIER	GEWINDESTIFT	PRISIONERO
7	25.2.1.08020	3	GRANO	SECURITY DOWEL	GRAIN	STIFT	PERNO DE TOPE
8	050.333	1	FRIZIONE	CLUTCH	FRICTION	FRIKTION	FRICCIÓN
9	31.02.00.1.08	2	DADO	NUT	ECROU	MUTTER	TUERCA
10	050.260	1	INVERTITORE DI MARCIA	SPEED REVERSER	INVERSEUR DE MARCHE	FAHRTWENDER	INVERSOR DE MARCHA
11	21.0.0.08025	6	VITE	SCREW	VIS	SCHRAUBE	TORNILLO
12	16.00.01.008	6	GROWER	GROWER	GROWER	GROWER	GROWER
13	15.0.0.00.008	6	RONDELLA PIANA	PLAIN WASHER	RONDELLE PLANE	ABSTANDSRING	ARANDELA LLANA
14	20.0.0.12035	4	VITE	SCREW	VIS	SCHRAUBE	TORNILLO
15	18.0.0.00.012	4	RONDELLA PIANA	PLAIN WASHER	RONDELLE PLANE	ABSTANDSRING	ARANDELA LLANA
16	050.317	1	MAGLIA DI GIUNZIONE	CHAIN JOINT	JOINT DE CHAÎNE	STECKGLIED	UNIÓN DE CADENA
17	045.054	1	SUPPORTO INVERTITORE	REVERSER SUPPORT	SUPPORT INVERSEUR	HALTERUNG FAHRTWENDER	SOPORTE INVERSOR
18	045.058	2	DISTANZIALE	SPACER	ENTRETOISE	ABSTANDSTUECK	SEPARADOR
19	045.057	1	SUPPORTO CAVO	CABLE SUPPORT	SUPPORT CABLE	KABELHALTERUNG	SOPORTE CABLE
20	15.1.0.00.008	2	RONDELLA PIANA	PLAIN WASHER	RONDELLE PLANE	ABSTANDSRING	ARANDELA LLANA
21	21.0.0.10030	6	VITE	SCREW	VIS	SCHRAUBE	TORNILLO
22		2	PRIGIONIERO	STUD	PRISONNIER	GEWINDESTIFT	PRISIONERO
23	21.0.0.10040	4	VITE	SCREW	VIS	SCHRAUBE	TORNILLO
24	15.0.0.00.010	8	RONDELLA PIANA	PLAIN WASHER	RONDELLE PLANE	ABSTANDSRING	ARANDELA LLANA
25	045.055	1	FLANGIA DI TRASMISSIONE	DRIVING FLANGE	BRIDE D'ENTRAINEMENT	ANTRIEBSFLANSCH	BRIDA TRANSMISIÓN
26	30.01.00.010	4	DADO AUTOBLOCCANTE	STOP NUT	ECROU DE SURETE	SPERRMUTTER	TUERCA AUTOTRABADORA
27	090.009	1	MOZZO PORTA ALBERO	SHAFT HUB	MOYEU ARBRE	WELLENNABE	CUBO EJE
28	31.01.00.0.10	4	DADO	NUT	ECROU	MUTTER	TUERCA
29	30.03.00.016	1	DADO AUTOBLOCCANTE	STOP NUT	ECROU DE SURETE	SPERRMUTTER	TUERCA AUTOTRABADORA
30	30.02.00.010	4	DADO AUTOBLOCCANTE	STOP NUT	ECROU DE SURETE	SPERRMUTTER	TUERCA AUTOTRABADORA
31	A62062RS	2	CUSCINETTO	BEARING	PALIER	LAGERSCHALE	COJINETE



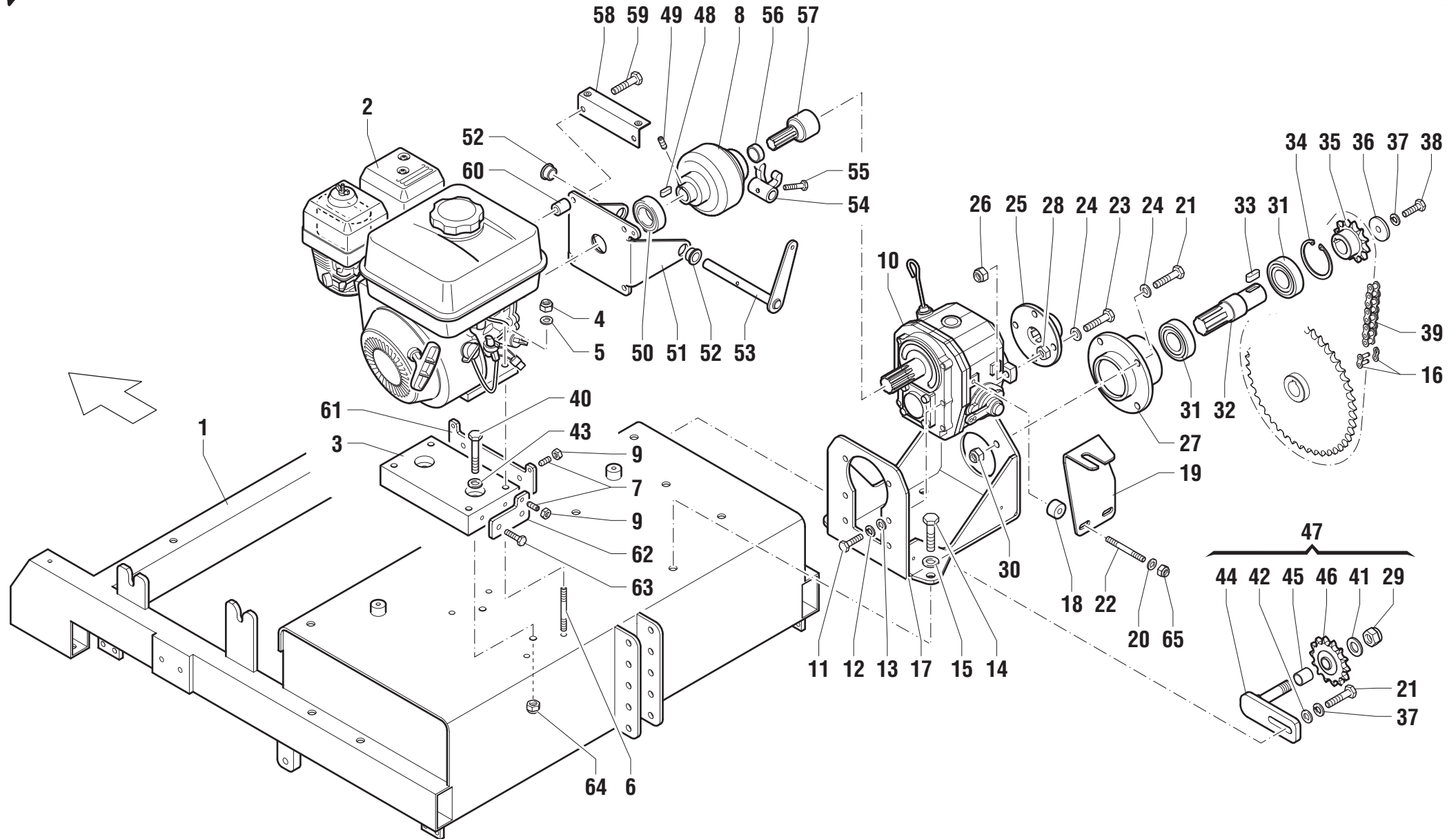

<i>Rif.</i>	<i>CODICE</i>	<i>Qty</i>	<i>Descrizione</i>	<i>Description</i>	<i>Designation</i>	<i>Benennung</i>	<i>Denominaciones</i>
32	090.008	1	ALBERO DI TRASMISSIONE	PROPELLER SHAFT	ARBRE DE TRANSMISSION	WELLE TRANSMISSION	ARBOL DE TRANSMISIÓN
33	35.1.0.08025	1	LINGUETTA	KEY	CLAVETTE	KEIL	CHAVETA
34	18.00.00.062	1	ANELLO ELASTICO	SNAP RING	ANNEAU RESSORT	SICHERUNGSRING	ANILLO ELASTICO
35	045.026	1	PIGNONE	PINION	PIGNON	RITZEL	PINON
36	15.1.0.01.010	1	RONDELLA	WASHER	RONDELLE	SCHEIBE	ARANDELA
37	16.00.01.010	2	GROWER	GROWER	GROWER	GROWER	GROWER
38	21.0.0.10025	1	VITE	SCREW	VIS	SCHRAUBE	TORNILLO
39	050.316	1	CATENA	CHAIN	CHAÎNE	KETTE	CADENA
40	20.0.0.10045	2	VITE	SCREW	VIS	SCHRAUBE	TORNILLO
41	15.0.0.00.016	1	RONDELLA PIANA	PLAIN WASHER	RONDELLE PLANE	ABSTANDSRING	ARANDELA LLANA
42	15.0.0.01.010	1	RONDELLA PIANA	PLAIN WASHER	RONDELLE PLANE	ABSTANDSRING	ARANDELA LLANA
43	16.01.00.010	2	RONDELLA ELASTICA	SPRING WASHER	RONDELLE ELASTIQUE	FEDERSCHEIBE	ARANDELA ELASTICA
44	045.024/A	1	SUPPORTO (TENDICATENA)	SUPPORT (CHAIN TIGHTENER)	SUPPORT (TENDEUR DE CHAINE)	LAGER (KETTENSANNER)	SOPORTE (TENSOR DE CADENA)
45	045.038	1	DISTANZIALE	SPACER	ENTRETOISE	ABSTANDSTUECK	SEPARADOR
46	050.318	1	CORONA	RING GEAR	COURONNE	KRANZ	CORONA
47	045.024	1	TENDICATENA COMPLETO	CHAIN TIGHTENER	TENDEUR DE CHAINE	KETTENSANNER	TENSOR DE CADENA
48		1	LINGUETTA MOTORE HONDA	KEY	CLAVETTE	KEIL	CHAVETA
49	25.2.1.08020	1	GRANO	SECURITY DOWEL	GRAIN	STIFT	PERNO DE TOPE
50	A60062RS	1	CUSCINETTO	BEARING	PALIER	LAGERSCHALE	COJINETE
51	045.094	1	SUPPORTO ALBERO FRIZIONE	CLUTCH SHAFT SUPPORT	SUPPORT ARBRE EMBRAYAGE	TRÄGER KUPPLUNGSWELLE	SOPORTE ÁRBOL EMBRAGUE
52	045.095	2	BOCCOLA ALBERO	CLUTCH SHAFT BUSHING	DOUILLE ARBRE EMBRAYAGE	BUCHSE KUPPLUNGSWELLE	CASQUILLO ÁRBOL EMBRAGUE
			INNESTO FRIZIONE				
53	045.092	1	ALBERO INNESTO FRIZIONE	CLUTCH SHAFT	ARBRE EMBRAYAGE	KUPPLUNGSWELLE	ÁRBOL EMBRAGUE
54	050.334	1	FORCELLA	FORK	FOURCHE	GABEL	HORQUILLA
55	21.0.0.06020	1	VITE	SCREW	VIS	SCHRAUBE	TORNILLO
56	045.096	1	DISTANZIALE MANICOTTO	SLEEVE SPACER	ENTRETOISE MANCHON	ABSTANDSTÜCK ROHR	ESPACIADOR MANGUITO
57	045.088	1	MANICOTTO TRASMISSIONE	TRANSMISSION SLEEVE	MANCHON TRANSMISSION	TRANSMISSIONSROHR	MANGUITO TRANSMISIÓN
58	045.087	1	ANGOLARE DI SUPPORTO	ANGLE IRON	CORNIERE	WINKELPROFIL	ANGULAR
59	21.0.0.08065	4	VITE	SCREW	VIS	SCHRAUBE	TORNILLO
60	045.093	4	BOCCOLA SUPPORTO FRIZIONE	CLUTCH SUPPORT BUSHING	DOUILLE SUPPORT EMBRAYAGE	BUCHSE KUPPLUNGSTRÄGER	CASQUILLO SOPORTE EMBRAG



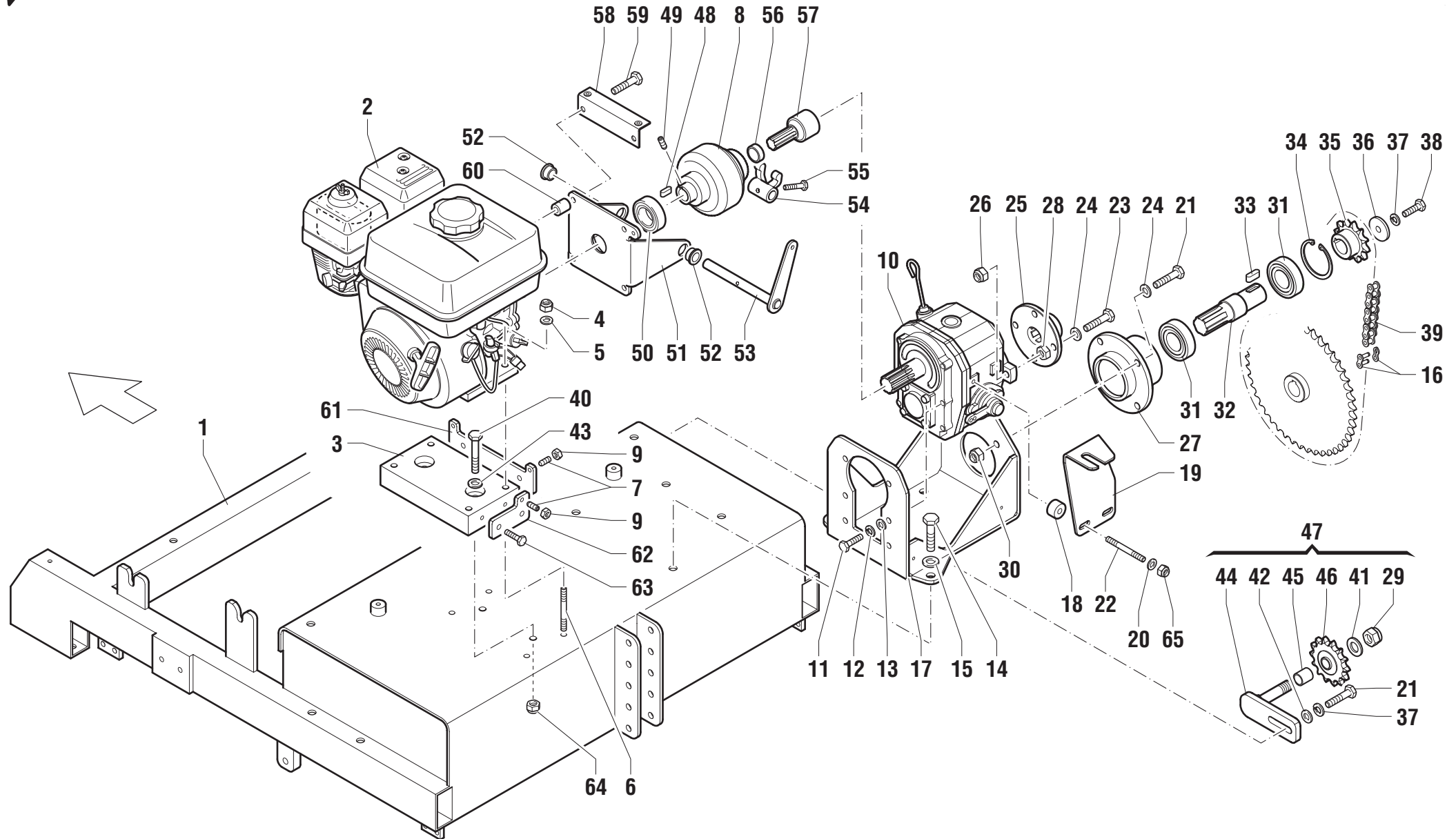

Rif.	CODICE	Qty	Descrizione	Description	Designation	Benennung	Denominaciones
61	045.060/B	4	PIATTO RISCONTRO MOTORE FRONTALE	FRONT ENGINE STOP PLATE	PLATEAU DE BUTEE MOTEUR FRONTAL	ANSCHLAGPLATTE VORDERER MOTOR	PLATILLO DE TOPE MOTOR FRONTAL
62	045.060/A	1	PIATTO RISCONTRO MOTORE LATERALE	SIDE ENGINE STOP PLATE	PLATEAU DE BUTEE MOTEUR LATERAL	ANSCHLAGPLATTE SEITLICHER MOTOR	PLATILLO DE TOPE MOTORE MOTOR LATERAL
63	21.0.0.08016	4	VITE	SCREW	VIS	SCHRAUBE	TORNILLO
64	30.02.00.010	2	DADO AUTOBLOCCANTE	STOP NUT	ECROU DE SURETE	SPERRMUTTER	TUERCA AUTOTRABADORA
65	30.02.00.008	2	DADO AUTOBLOCCANTE	STOP NUT	ECROU DE SURETE	SPERRMUTTER	TUERCA AUTOTRABADORA



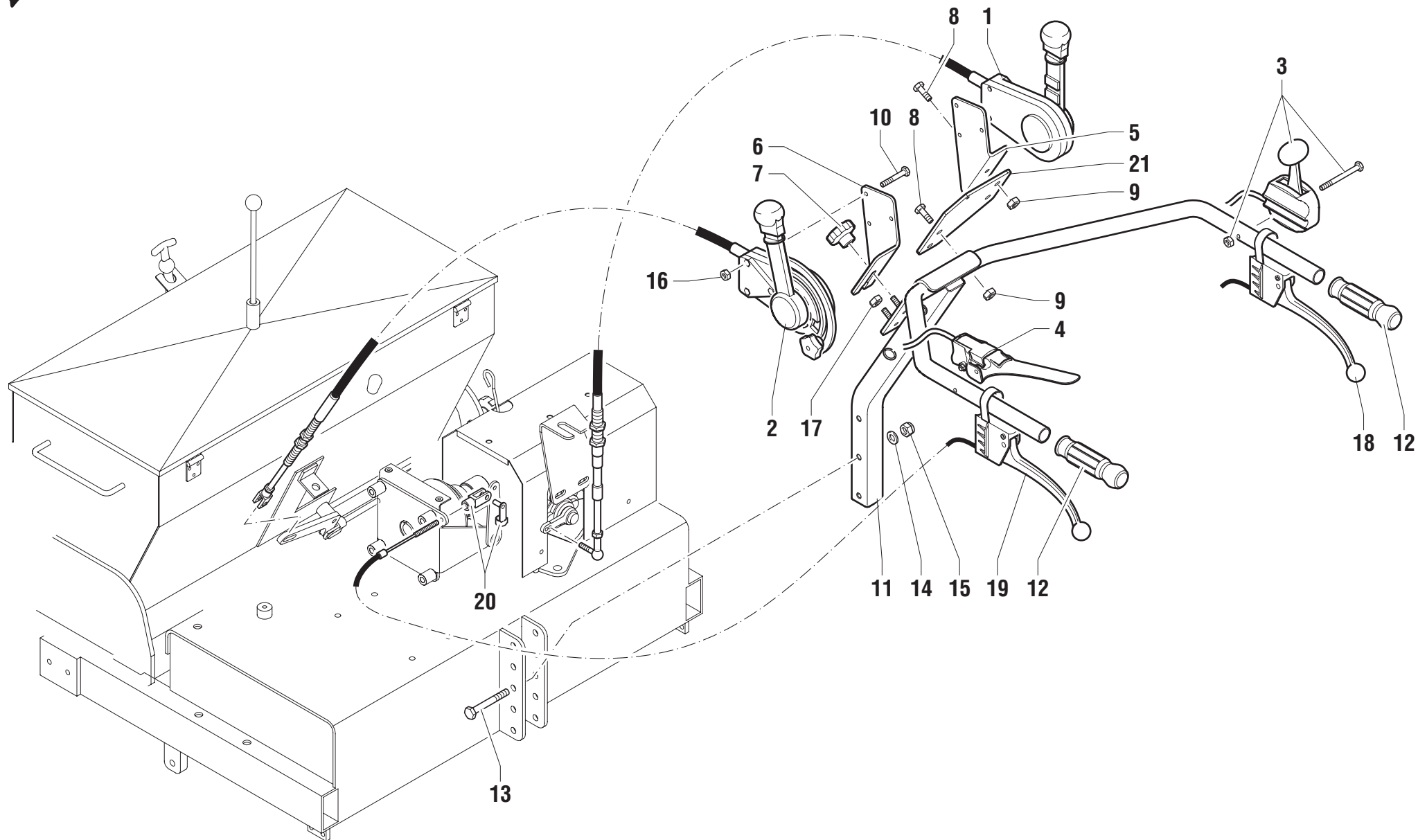

<i>Rif.</i>	<i>CODICE</i>	<i>Qty</i>	<i>Descrizione</i>	<i>Description</i>	<i>Designation</i>	<i>Benennung</i>	<i>Denominaciones</i>
1	050.306	1	LEVA AVANZAMENTO	SPEED LEVER	LEVIER AVANCEMENT	HEBEL VORWÄRTS	PALANCA DE AVANCE
2	050.307	1	LEVA APERTURA SEMINATRICE	SEEDER OPENING LEVER	LEVIER OUVERTURE SEMOIR	ÖFFNUNGSHEBEL DRILLMASCHINE	PALANCA APERTURA SEMBRADORA
3	050.308	1	LEVA ACCELERATORE	ACCELERATOR	ACCELERATEUR	BESCHLEUNIGER	ACELERADOR
4	050.309	1	LEVA UOMO PRESENTE	DEAD MAN LEVER	LEVIER HOMME PRESENT	TOTMANN-HEBEL	PALANCA HOMBRE PRESENTE
5	045.067	1	SUPPORTO LEVA DESTRO	RIGHT LEVER SUPPORT	SUPPORT LEVIER DROIT	HEBELHALTERUNG RECHTS	SOPORTE PALANCA DERECHO
6	045.066	1	SUPPORTO LEVA SINISTRO	LEFT LEVER SUPPORT	SUPPORT LEVIER GAUCHE	HEBELHALTERUNG LINKS	SOPORTE PALANCA IZQUIERDO
7	050.030	1	VOLANTINO	HAND WHELL	VOLANT A MAN	HANDRAD	VOLANTE
8	21.0.0.08025	2	VITE	SCREW	VIS	SCHRAUBE	TORNILLO
9	30.02.00.008	2	DADO AUTOBLOCCANTE	STOP NUT	ECROU DE SURETE	SPERRMUTTER	TUERCA AUTOTRABADORA
10	21.0.0.06050	6	VITE	SCREW	VIS	SCHRAUBE	TORNILLO
11	045.065	1	MANUBRIO	HANDLEBAR	GUIDON	LENKER	MANILLAR
12	050.310	2	MANOPOLA	KNOB	POIGNEE	GRIFF	POMO
13	21.0.0.10070	2	VITE	SCREW	VIS	SCHRAUBE	TORNILLO
14	15.0.0.00.010	2	RONDELLA PIANA	PLAIN WASHER	RONDELLE PLANE	ABSTANDSRING	ARANDELA LLANA
15	30.02.00.010	2	DADO AUTOBLOCCANTE	STOP NUT	ECROU DE SURETE	SPERRMUTTER	TUERCA AUTOTRABADORA
16	30.02.00.006	6	DADO	NUT	ECROU	MUTTER	TUERCA
17	045.063	1	BOCCOLA GUIDA SUPP. LEVA	LEVER SUPPORT GUIDE BUSHING	DOUILLE DE GUIDAGE	FÜHRUNGSBÜCHSE	CASQUILLO DE GUÍA
				SUPPORT LEVIER	HEBELHALTERUNG	SOPORTE PALANCA	
18	050.321	1	LEVA FRENO	BRAKE LEVER	LEVIER FREIN	BREMSHEBEL	PALANCA FRENO
19	050.339/A	1	LEVA FRIZIONE	CLUTCH LEVER	LEVIER EMBRAYAGE	KUPPLUNGSHEBEL	PALANCA EMBRAGUE
20	050.339/B	1	FORCELLA	FORK	FOURCHE	GABEL	HORQUILLA
21	047.067/A	1	PIASTRA DISTANZIALE	LEVER SUPPORT	PLAQUE INTERCALAIRE	ABSTANDPLATTE HEBELSTÜTZE	PLACA ESPACIADORA
			SUPPPORTO LEVA	SPACING PLATE	SUPPORT LEVIER		SOPORTE PALANCA





CARTER E ACCESSORI
COVERS AND ACCESSORIES
CARTERS ET ACCESSOIRES
SCHUTZABDECKUNGEN UND ZEBÖHR
CÁRTERES Y ACCESORIOS

Tav. 07.0

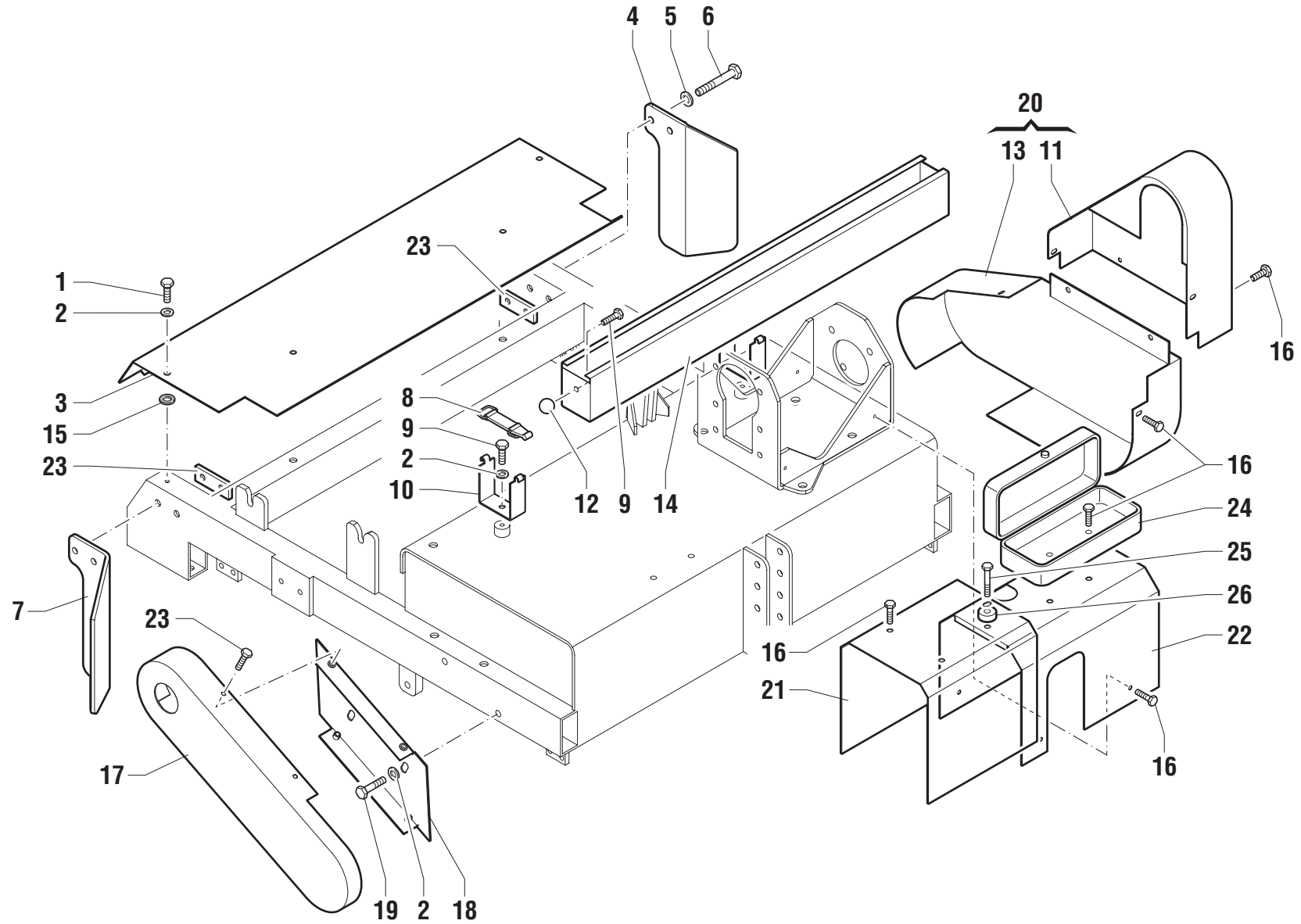

<i>Rif.</i>	<i>CODICE</i>	<i>Qty</i>	<i>Descrizione</i>	<i>Description</i>	<i>Designation</i>	<i>Benennung</i>	<i>Denominaciones</i>
1	21.0.0.08020	4	VITE	SCREW	VIS	SCHRAUBE	TORNILLO
2	15.0.0.00.008	10	RONDELLA PIANA	PLAIN WASHER	RONDELLE PLANE	ABSTANDSRING	ARANDELA LLANA
3	045.053	1	CARTER ANTERIORE	FRONT COVER	CARTER AVANT	VORDERE SCHUTZABDECKUNG	CÁRTER ANTERIOR
4	045.064/DX	1	PIASTRA PARACOLPI	SHOCK-ABSORBING PLATE	PLAQUE AMORTISSEUR	STOSSDÄMPFENDE PLATTE	PLACA AMORTIGUADORA
5	15.0.0.00.010	4	RONDELLA PIANA	PLAIN WASHER	RONDELLE PLANE	ABSTANDSRING	ARANDELA LLANA
6	21.0.0.10030	4	VITE	SCREW	VIS	SCHRAUBE	TORNILLO
7	045.064/SX	1	PIASTRA PARACOLPI	SHOCK-ABSORBING PLATE	PLAQUE AMORTISSEUR	STOSSDÄMPFENDE PLATTE	PLACA AMORTIGUADORA
8	050.299	2	TIRANTE IN GOMMA	RUBBER TIE-ROG	TIRANT CAOUTCHOUC	GUMMI-ZUGSTANGE	TIRANTE DE GOMA
9	21.0.0.08016	3	VITE	SCREW	VIS	SCHRAUBE	TORNILLO
10	045.052	2	SUPPORTO	SUPPORT	SUPPORT	LAGER	SOPORTE
11	045.048/B	1	CARTER SUPERIORE	TOP COVER	CARTER SUPERIEUR	OBERE SCHUTZABDECKUNG	CÁRTER SUPERIOR
12	050.068	1	POMELLO	BALL-GRIP	POMMEAU	KUGELGRIFF	POMO
13	045.048/A	1	CARTER INFERIORE	BOTTOM COVER	CARTER INFERIEUR	UNTERE SCHUTZABDECKUNG	CÁRTER INFERIOR
14	045.051	1	SCATOLA RACCOLTA SEME	SEED BOX	BOITE GRAINES	SAMENKASTEN	CAJA SEMILLAS
15	050.165	4	ANTIVIBRANTE	INSULATOR	PIECE ANTIVIBRATILE	SCHWINGUNGSDÄMPFER	ANTIVIBRADOR
16	21.0.0.06016	16	VITE	SCREW	VIS	SCHRAUBE	TORNILLO
17	045.037	1	CARTER INTERNO	INTERNAL COVER FOR	CARTER INTERIEUR	INNERE SCHUTZABDECKUNG	CÁRTER INTERIOR
			CATENA SEMINATRICE	SEEDER CHAIN	CHAINE SEMOIR	DRILLMASCHINENKETTE	CADENA SEMBRADORA
18	045.036	1	CARTER ESTERNO	EXTERNAL COVER FOR	CARTER EXTERIEUR	AUSSERE SCHUTZABDECKUNG	CÁRTER EXTERIOR
			CATENA SEMINATRICE	SEEDER CHAIN	CHAINE SEMOIR	DRILLMASCHINENKETTE	CADENA SEMBRADORA
19	21.0.0.08025	2	VITE	SCREW	VIS	SCHRAUBE	TORNILLO
20	045.048	1	CARTER CATENA TRASMISS.	DRIVING CHAIN COVER	CARTER CHAINE ENTRAINEMENT	SCHUTZABDECKUNG ANTRIEBSKETTE	CÁRTER CADENA TRANSMISIÓN
21	045.049/A	1	CARTER	CASING	CARTER	SCHUTZABDECKUNG	CÁRTER
22	045.059/C	1	CARTER	CASING	CARTER	SCHUTZABDECKUNG	CÁRTER
23	045.068	2	PIATTO FILETTATO	THREADED PLATE	PLATEAU FILETE	GEWINDEPLATTE	PLATO CON ROSCA
24	050.327	1	CASSETTA ATTREZZI	TOOLBOX	BOITE PORTE OUTILS	WERKZEUGKASTEN	CAJA HERRAMIENTAS
25	21.0.0.06025	1	VITE	SCREW	VIS	SCHRAUBE	TORNILLO
26	045.012	1	DISTANZIALE	SPACER	ENTRETOISE	ABSTANDSTUECK	SEPARADOR





MONTAGGIO RULLO ANTERIORE E POSTERIORE
FRONT AND REAR ROLLER ASSEMBLY
MONTAGE ROULEAUX AVANT ET ARRIERE
MONTAGE VORDERE UND HINTERE ROLLEN
MONTAGE RODILLOS DELANTERO Y TRASERO

Tav. 08.0

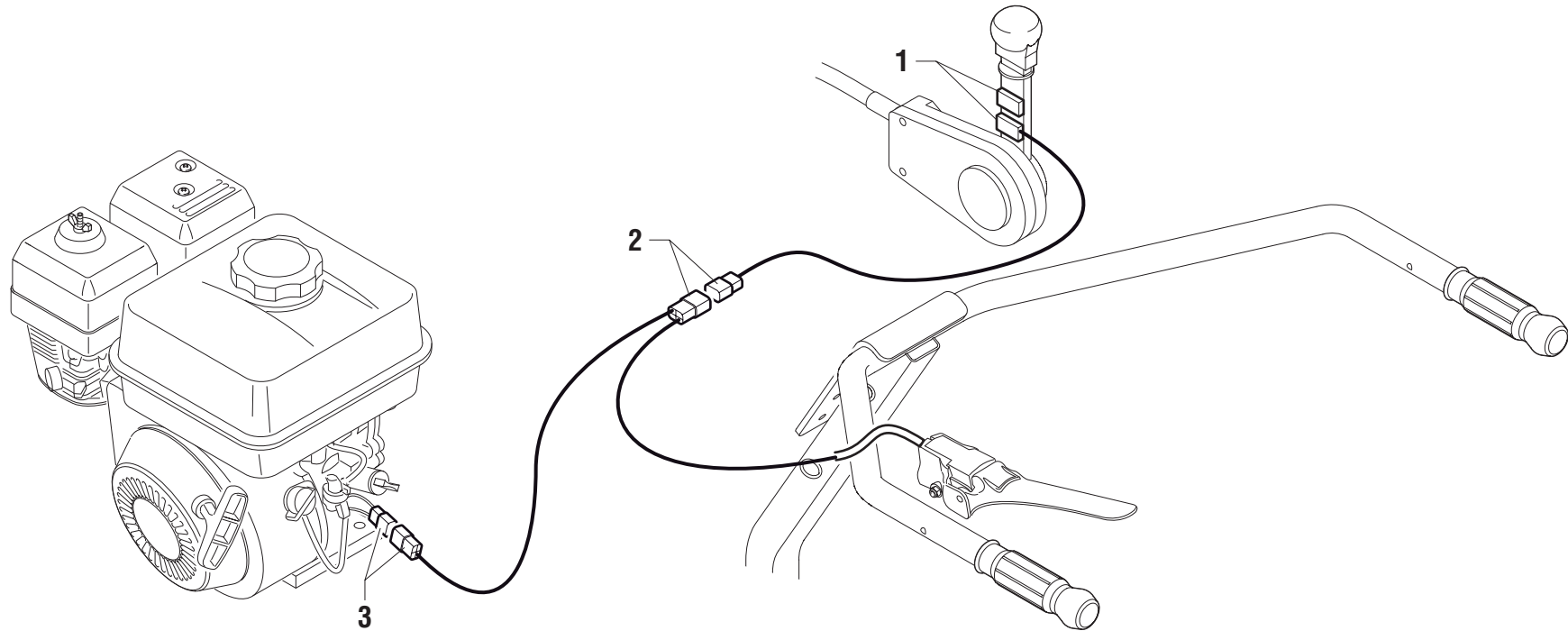



MONTAGGIO RULLO ANTERIORE E POSTERIORE
FRONT AND REAR ROLLER ASSEMBLY
MONTAGE ROULEAUX AVANT ET ARRIERE
MONTAGE VORDERE UND HINTERE ROLLEN
MONTAGE RODILLOS DELANTERO Y TRASERO

OPTIONAL

Tav. 09.0

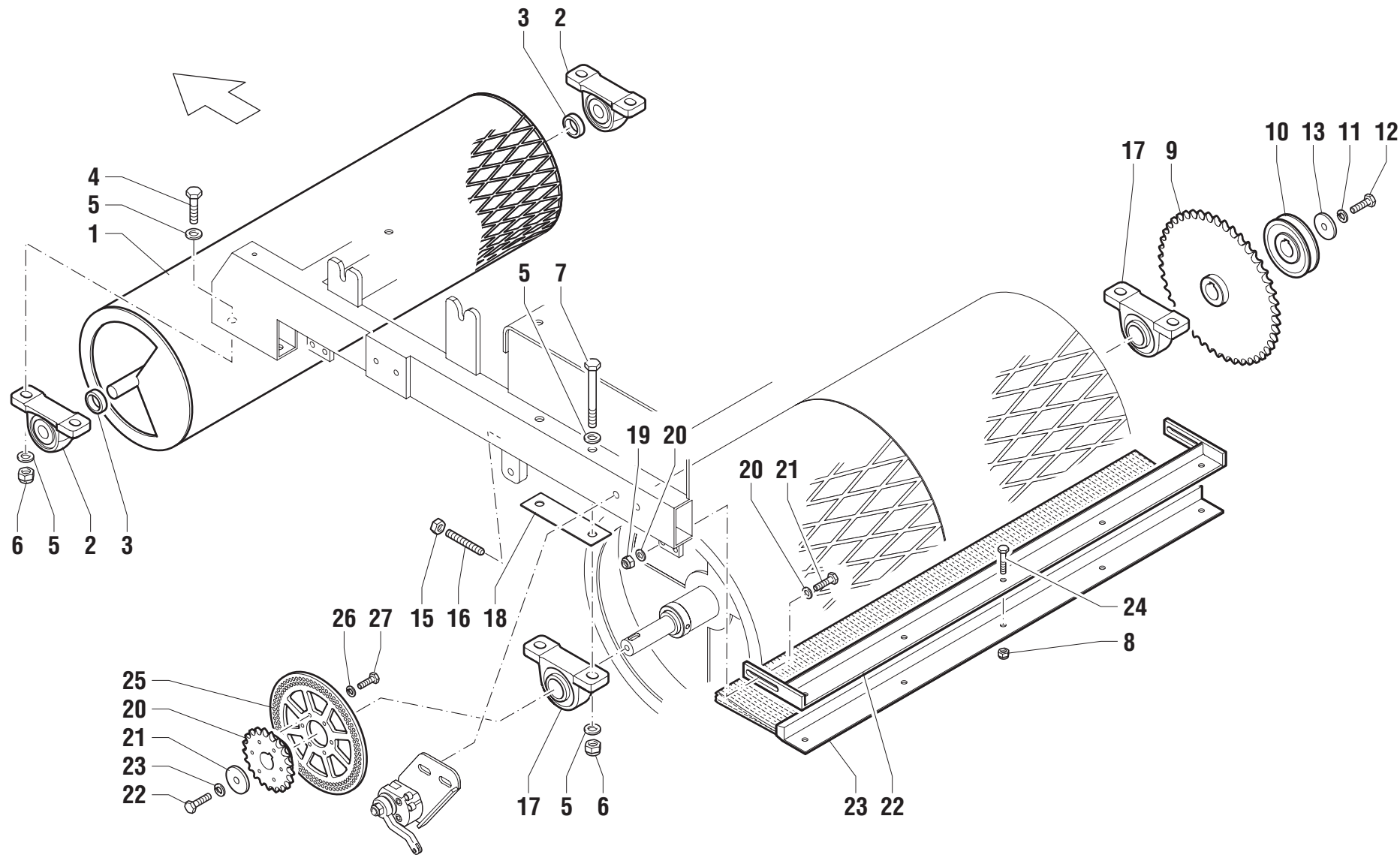

<i>Rif.</i>	<i>CODICE</i>	<i>Qty</i>	<i>Descrizione</i>	<i>Description</i>	<i>Designation</i>	<i>Benennung</i>	<i>Denominaciones</i>
1	045.077	1	RULLO ANTERIORE	FRONT ROLLER	ROULEAU AVANT	VORDERE ROLLE	RODILLO DELANTERO
2	AUCP204	2	SUPPORTO	SUPPORT	SUPPORT	LAGER	SOPORTE
3	045.029	2	DISTANZIALE	SPACER	ENTRETOISE	ABSTANDSTUECK	SEPARADOR
4	20.0.0.12040	4	VITE	SCREW	VIS	SCHRAUBE	TORNILLO
5	15.0.0.00.012	16	RONDELLA PIANA	PLAIN WASHER	RONDELLE PLANE	ABSTANDSRING	ARANDELA LLANA
6	30.02.00.012	8	DADO AUTOBLOCCANTE	STOP NUT	ECROU DE SURETE	SPERRMUTTER	TUERCA AUTOTRABADORA
7	20.0.0.12110	4	VITE	SCREW	VIS	SCHRAUBE	TORNILLO
8	30.03.00.006	5	DADO AUTOBLOCCANTE	STOP NUT	ECROU DE SURETE	SPERRMUTTER	TUERCA AUTOTRABADORA
9	045.025	1	CORONA	RING GEAR	COURONNE	KRANZ	CORONA
10	045.021	1	PULEGGIA DI TRASMISSIONE	DRIVING PULLEY	POULIE MOTRICE	ANTRIEBSSCHEIBE	POLEA MOTRIZ
11	16.01.00.010	2	GROWER	GROWER	GROWER	GROWER	GROWER
12	21.0.0.10025	2	VITE	SCREW	VIS	SCHRAUBE	TORNILLO
13	15.1.0.01.010	2	RONDELLA	WASHER	RONDELLE	SCHEIBE	ARANDELA
14	045.027	1	PIGNONE	PINION	PIGNON	RITZEL	PINON
15	31.02.00.1.08	2	DADO	NUT	ECROU	MUTTER	TUERCA
16	25.0.0.08060	2	BARRA FILETTATA	THREADED BAR	BARE FILETEE	STANGE SCHRAUBEN	BARRA FILETEAR
17	AUCP205	2	SUPPORTO	SUPPORT	SUPPORT	LAGER	SOPORTE
18	045.022	2	DISTANZIALE PER SUPPORTO	SUPPORT SPACER	ENTRETOISE SUPPORT	ABSTANDSTÜCK HALTERUNG	ESPACIADOR SOPORTE
19	30.01.00.008	4	DADO AUTOBLOCCANTE	STOP NUT	ECROU DE SURETE	SPERRMUTTER	TUERCA AUTOTRABADORA
20	15.0.0.00.008	8	RONDELLA PIANA	PLAIN WASHER	RONDELLE PLANE	ABSTANDSRING	ARANDELA LLANA
21	21.0.0.08025	4	VITE	SCREW	VIS	SCHRAUBE	TORNILLO
22	045.078	1	SUPPORTO	SUPPORT	SUPPORT	LAGER	SOPORTE
23	036.046	1	SPAZZOLA	BRUSH	BROSSE	BUERSTE	CEPILLO
24	21.0.0.06020	5	VITE	SCREW	VIS	SCHRAUBE	TORNILLO
25	045.040	1	DISCO FRENO	BRAKE DISC	DISQUE DE FREIN	BREMSSCHEIBE	DISCO FRENO
26	15.0.0.00.005	6	RONDELLA PIANA	PLAIN WASHER	RONDELLE PLANE	ABSTANDSRING	ARANDELA LLANA
27	21.0.0.05016	6	VITE	SCREW	VIS	SCHRAUBE	TORNILLO





MONTAGGIO RULLO ANTERIORE
FRONT ROLLER ASSEMBLY
MONTAGE ROULEAUX AVANT
MONTAGE VORDERE ROLLEN
MONTAGE RODILLOS DELANTERO

OPTIONAL

Tav. 10.0

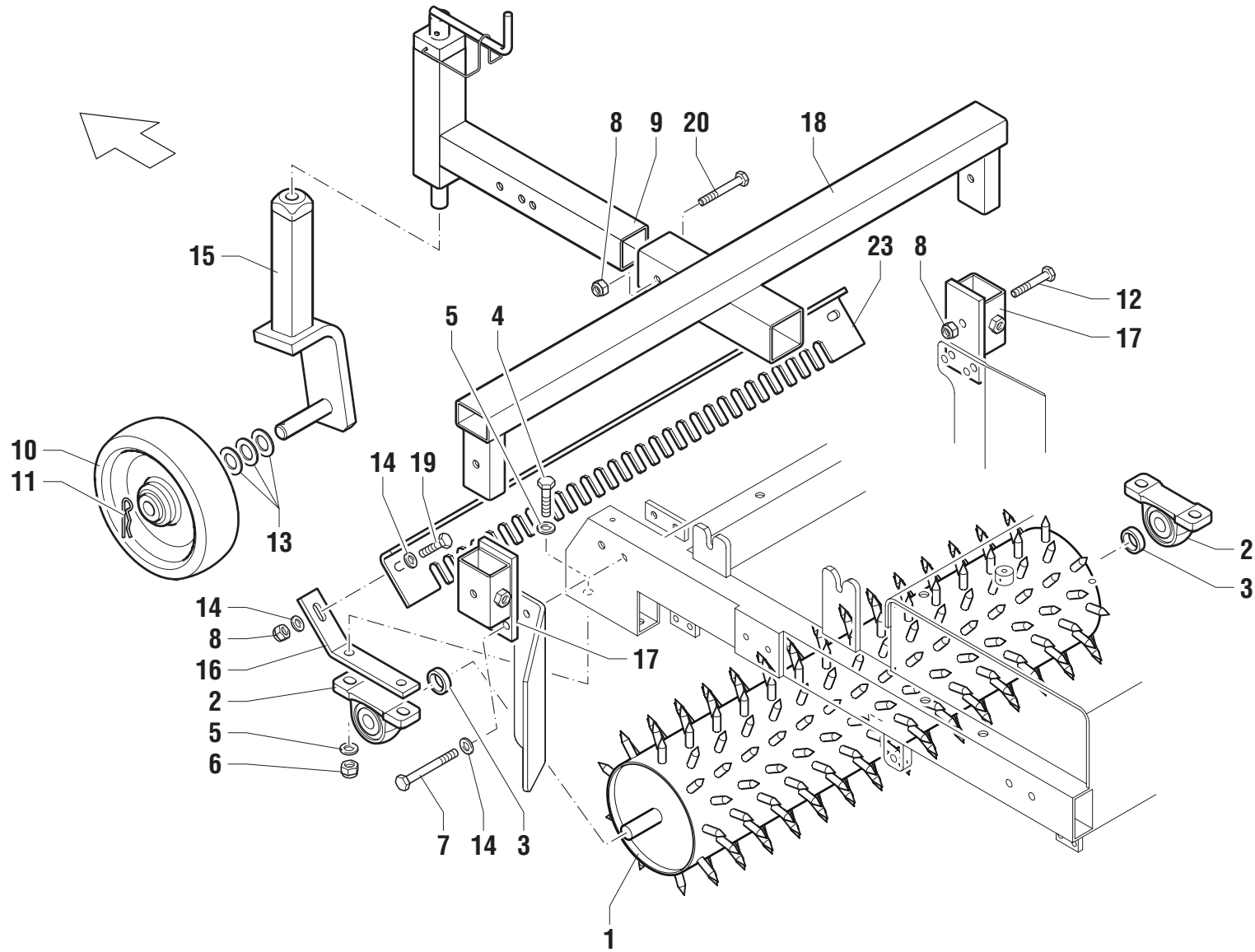

<i>Rif.</i>	<i>CODICE</i>	<i>Qty</i>	<i>Descrizione</i>	<i>Description</i>	<i>Designation</i>	<i>Benennung</i>	<i>Denominaciones</i>
1	045.080	1	RULLO ANTERIORE	FRONT ROLLER	ROULEAU AVANT	VORDERE ROLLE	RODILLO DELANTERO
2	AUCP204	2	SUPPORTO	SUPPORT	SUPPORT	LAGER	SOPORTE
3	045.029	2	DISTANZIALE	SPACER	ENTRETOISE	ABSTANDSTUECK	SEPARADOR
4	20.0.0.12040	4	VITE	SCREW	VIS	SCHRAUBE	TORNILLO
5	15.0.0.00.012	8	RONDELLA PIANA	PLAIN WASHER	RONDELLE PLANE	ABSTANDSRING	ARANDELA LLANA
6	30.02.00.012	4	DADO AUTOBLOCCANTE	STOP NUT	ECROU DE SURETE	SPERRMUTTER	TUERCA AUTOTRABADORA
7	21.0.0.10035	4	VITE	SCREW	VIS	SCHRAUBE	TORNILLO
8	30.02.00.010	3	DADO AUTOBLOCCANTE	STOP NUT	ECROU DE SURETE	SPERRMUTTER	TUERCA AUTOTRABADORA
9	045.085	1	SUPPORTO REGISTRO RUOTINO	WHEEL ADJUSTMENT	SUPPORT DISPOSITIF DE	HALTERUNG EINSTELLSCHRAUBE	SOPORTE DISPOSITIVO
				SCREW SUPPORT	REGLAGE ROULETTE	LAUFROLLE	DE AJUSTE RUE
10	050.335	1	RUOTA	WHEEL	ROUE	RAD	RUEDA
11		1	COPIGLIA	COTTER PIN	GOUPILLE	SPLINT	CLAVIJA
12	21.0.0.10070	2	VITE	SCREW	VIS	SCHRAUBE	TORNILLO
13	15.0.0.00.020	3	RONDELLA	WASHER	RONDELLE	SCHEIBE	ARANDELA
14	15.0.0.00.010	8	RONDELLA PIANA	PLAIN WASHER	RONDELLE PLANE	ABSTANDSRING	ARANDELA LLANA
15	045.086	1	FORCELLA PORTA RUOTINO	WHEEL HOLDER FORK	FOURCHE PORTE ROULETTE	GABEL LAUFROLLENTRÄGER	HORQUILLA PORTA RUEDA
16	045.082	2	SUPPORTO LAMIERA	ROLLER CLEANING	SUPPORT TOLE NETTOYAGE	HALTERUNG REINIGUNGSBLECH	SOPORTE CHAPA
			PULISCI RULLO	PLATE SUPPORT	ROULEAU	WALZE	LIMPIA-RODILLO
17	045.083	2	SUPPORTO ESTERNO	EXTERNAL SUPPORT FOR	SUPPORT EXTERIEUR BATI	ÄUSSERE HALTERUNG RAHMEN	SOPORTE EXTERIOR TE
			TELAIO PORTA RUOTINO	WHEEL HOLDING FRAME	PORTE ROULETTE	LAUFROLLENTRÄGER	BASTIDOR PORTA RUEDA
18	045.084	1	TELAIO PORTA RUOTINO	WHEEL HOLDING FRAME	BATI PORTE ROULETTE	RAHMEN LAUFROLLENTRÄGER	BASTIDOR PORTA RUEDA
19	21.0.0.10030	2	VITE	SCREW	VIS	SCHRAUBE	TORNILLO
20	21.0.0.10070	1	VITE	SCREW	VIS	SCHRAUBE	TORNILLO

